

*Innovative solutions for controlling mechanical movement*

# **MANAGING MOTION**

**UTILIZING HELI-CAL<sup>®</sup> FLEXURE TECHNOLOGY**

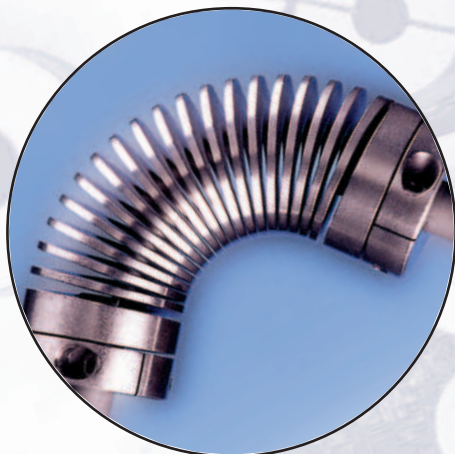
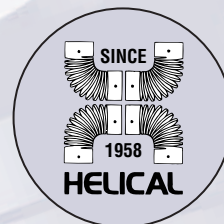

**Helical Products Company, Inc.**

**CONTENTS**

**THE HELI-CAL FLEXURE**

Now You Can Dream..... 3  
 The HELI-CAL Flexure Problem Solver ..... 4  
 Design Benefits of the Flexure ..... 6  
 Operating Characteristics ..... 6

**HELICAL FLEXURE FLEXIBLE COUPLINGS**

HELICAL Flexure, Basic Product Summary .....9  
 A Series, Aluminum .....10  
 H Series, Stainless Steel .....10  
 DS Series, Aluminum .....12  
 MC Series, Stainless Steel and Aluminum .....14  
 W Series, Stainless Steel and Aluminum .....16  
 Special Bore Configurations .....18  
 PF Series, Stainless Steel and Aluminum.....20

**ACCESSORY PRODUCTS**

Adapter Hubs ..... 22  
 Bore Reducers ..... 22  
 Shaft Collars ..... 23  
 Solid Couplings ..... 23

**IDEA STIMULATORS**

X-Series Radial Slot Coupling ..... 24  
 A New Angle on Universal Joints ..... 26  
 Flexure Attachments that Make Sense ..... 27  
 What is a Machined Spring? ..... 28

**PLUS**

Engineering Proposal Form ..... 29  
 Literature Request Form..... 30  
 Philosophy ..... inside back cover  
 Representation ..... back cover

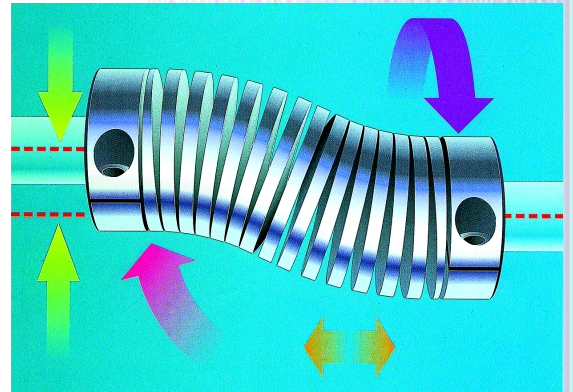

**Often imitated, never duplicated.**

HELICAL® Flexure, flexible couplings are machined from single piece, homogenous high-strength materials into helical (curved beam) configurations which eliminate elastomeric elements like rubber bushings, spiders, rubber discs and pads. Helical couplings compensate for shaft misalignment and work at high speed, transmitting high torque at a constant velocity. There is zero backlash. No maintenance is needed.

Helical couplings provide dynamic stability and vibration-free, smooth bearing loads, even at misaligned positions. Helical couplings find applications in petrochemical plants, instrumentation, encoders, lead screws, ball screws, air cooling units, pumps, machine tools, CNC machines, duplicators, computer peripherals, wind power generators, anywhere there is a need for managing motion.

**Six reasons why you should buy HELICAL**

**State-of-the-art, single piece, flexible (and torsionally stiff) couplings, utilizing the HELI-CAL Flexure.**

- ◆ No maintenance, no backlash, no lubrication, constant velocity.

**Engineering collaboration**

- ◆ Technical consultation (free).

**Quality product**

- ◆ Over 40 years experience in perfecting manufacturing machinery and procedures used to produce HELI-CAL Flexure couplings that are of consistent quality.

**Service/on time shipping**

- ◆ We do what we say we'll do e.g.- if we say, shipment in five working days we mean shipment in five working days.

**Originator of HELI-CAL Flexure couplings**

- ◆ Over 7,500 successful coupling designs; over 25,000 customers served.

**Total product offerings**

- ◆ In addition to a full line of standard couplings, the HELI-CAL Flexure can accommodate a variety of design requirements, such as special/customized end attachments like tangs, clamps, flanges or threaded ends.



**Helical Products Company, Inc.**  
 901 West McCoy Lane  
 P.O. Box 1069  
 Santa Maria, CA 93456-1069 USA

## Now You Can Dream . . .

The inspiration for the HELI-CAL Flexure, the cylindrical helix ingredient for our basic Helical product lines, came from the observation that one piece, "flexured" flexible couplings offered maximum versatility in terms of form, function and reliability.

Over time, the adaptability of the HELI-CAL Flexure has helped to solve thousands of mechanical misalignment and motion control problems.

The unique, mechanical characteristics of the "Flexure" have enabled Helical Products Company, Inc. to develop a series of highly versatile, "flexured" products which can compensate for irregularities such as angular and skewed misalignment, parallel offset and axial motion. All of this can be accomplished while maintaining constant rotational velocity and smooth bearing loads.

## Here's the HELI-CAL Flexure . . .

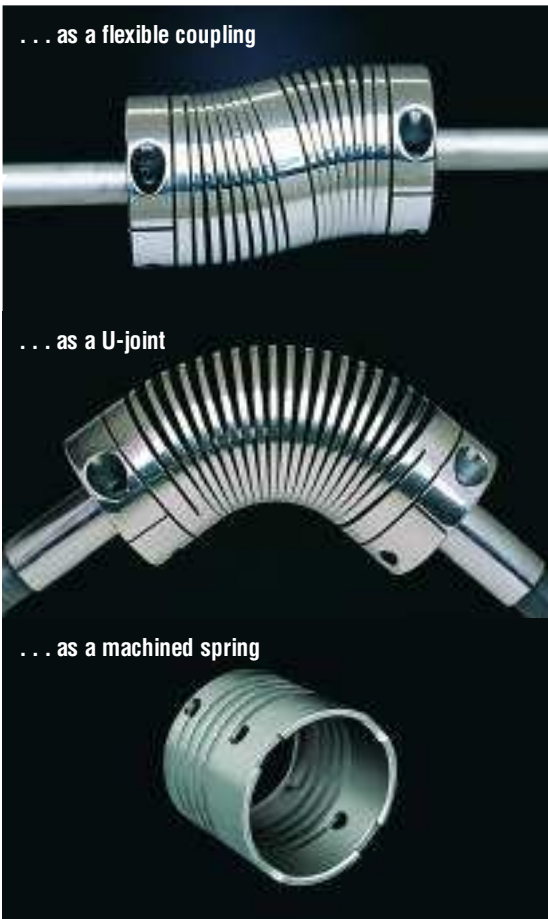

The HELI-CAL Flexure is a flexible helix (curved beam) machined from one piece of material into a specific configuration that incorporates special design requirements, performance features and/or characteristics.

Helical's product lines today include miniature flexible couplings, u-joints, machined springs, power transmission flexible couplings, plus, accessory products such as bore reducers, adapter hubs, shaft collars and solid couplings.

The following pages present the many advantages of HELI-CAL Flexure technology. The charts, data and information are based on our "standard" series of one-piece, flexible couplings, which are usable for a multitude of applications. As you become acquainted with the Flexure, you will see how versatile it can be, with for example, specials, machined springs, u-joints, and attachments. You will see also how the HELI-CAL Flexure can have a positive and marked impact on system performance, production efficiencies and overall cost savings.

If you do not see it here, just contact us.

Our application engineers can design, develop and produce a custom HELI-CAL Flexure to meet your specific requirements. 

## Coil Width

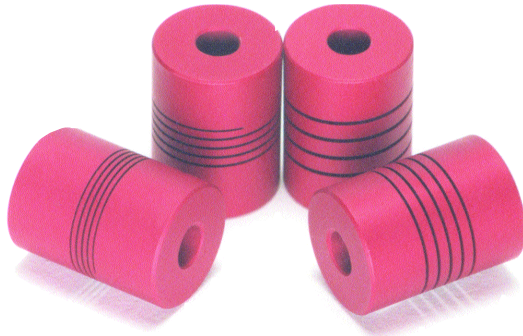

By varying the thickness of the coils, a Flexure can accommodate increasing amounts of torque and radial loads. The designer may specify torsional stiffness and compression spring rates independent of other factors.

### Connecting Dreams with Design Solutions: The HELI-CAL Flexure Problem Solver

#### Freedom of design... for maximum versatility

The Helical hallmark is flexibility in form and function. Designed from the start with your goals in mind and manufactured to exacting specifications, the HELI-CAL Flexure offers many problem-solving, performance-enhancing features.

#### Coil configuration

The individual performance capability of each Flexure is determined by: coil width, inside diameter, number of coils, number of starts and material. Altering any one of these factors changes the performance characteristics of the "Flexure."

For example, the HELI-CAL Flexures illustrated display identical outside diameters and lengths. The effects of their variable characteristics—such as coil width, inside diameter, number of coils and starts are explained in the adjacent pictures.

#### Coil widths and inside diameters

As the coil width or inside diameter are changed such aspects as *torque...angular misalignment (bending moment)... parallel offset (radial load)... torsional stiffness... and compression spring rate*, are altered.

## Inside Diameter



When the inside diameter changes, so does the torque capacity, torsional stiffness and axial spring rates, without restricting your choice of bore sizes.

#### Number of coils

As the number of coils is changed, all of the characteristics except the torque capacity are affected.

#### Number of coil starts

- 1) A single start design has one continuous coil.
- 2) A double start has a second coil starting 180 degrees from the first.
- 3) A triple start has three interwound coils, each spaced 120 degrees apart.

When a multi-start helix is used (double or triple), the effect is to increase the torque capacity and torsional stiffness while reducing misalignment capabilities (angular and parallel).

#### Material

The proper material used in the manufacture of any HELI-CAL Flexure affects much more than just torque capacity. Factors such as elasticity, fatigue, corrosion resistance, mass, magnetic permeability, operating temperature, availability and cost also play important roles. High strength materials such as 17-4PH CRES\*, 15-5 PH, C300, BETA C Titanium and 7075-T6 Aluminum, are just a few of the common choices for meeting design and performance needs.

\*CRES - Corrosion resistant steel

## Number of Coils



When the number of coils is changed the torque capability remains unaffected. All of the other characteristics change.

### Attachments

In addition to being able to alter the characteristics of the HELI-CAL Flexure, you may have your attachment method integrated into the final product.

Typical attachment options might include:

- integral clamps
- set screws
- set screw at one end and an integral clamp at the other
- pins
- slotted hubs
- flanges
- gears
- removable caps
- threaded bores with a wrench flat
- or . . . whatever your design requires

## Number of Coil Starts



Multiple, (typically two) helical beams provide high torsional stiffness. Shown: single, double and triple start.

### Bore variety

Helical Flexures may be engineered to include a variety of bore configurations. These variations include round, threaded, single or double-D, spline, keyway, tapered or ... your choice!

The HELI-CAL Flexure or flexible coil section of the coupling can be custom designed and manufactured to your specifications. Whether your considerations include high torque, angular or parallel misalignment, critical torsional stiffness, precise compression spring rates, or special end connections, chances are excellent that the HELI-CAL Flexure will meet or exceed your particular design requirements. 

#### ***The HELI-CAL Flexure, Basic Product Summary,***

(page 9), summarizes our basic series of HELI-CAL Flexure couplings. By referring to various charts and coupling descriptions, you will see how you can select a product that meets your design parameters. (See pages 10-26 for product specifics)

For more information or engineering assistance, please contact us.

**Angular****Design Benefits of the Flexure****More than a coupling**

The HELI-CAL Flexure concept brings enormous design flexibility to your applications. Depending on your needs, the Flexure can serve as a flexible shaft coupling, universal joint, spring clutch, machined spring or your own unique specialized component.

**Adaptability**

The Flexure's ability to accommodate various performance characteristics and Helical's ability to integrate attachments directly enhances your freedom to design.

**One-piece integrity**

Not only does the Flexure integrate multiple functions and parts into a single compact unit—no moving parts, no maintenance and no backlash—it can incorporate complex attachments.

**State-of-the-art**

High quality performance is achieved with magnetic or non-magnetic corrosion-resistant stainless steel, as well as aluminum alloys. Flexures are also successfully manufactured using various materials such as Delrin™ and titanium.

**Operating Characteristics****Misalignment compensation**

The flexing capacity of the HELI-CAL Flexure can compensate for a variety of misalignments, including parallel, angular and skewed (three-dimensional) misalignment. The Flexure solutions for these misalignment situations are shown in the adjacent photographs.

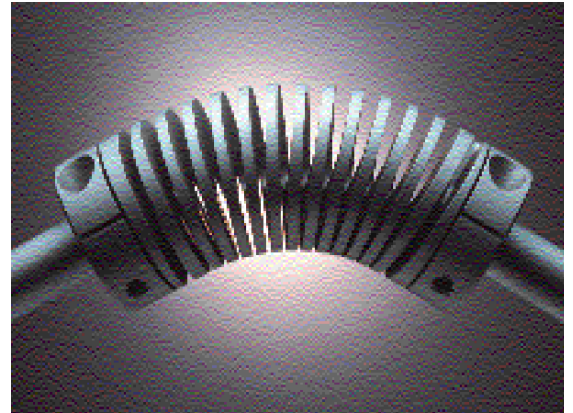

Angular misalignment is the easiest form of misalignment for most couplings to accept, and thus one of the most practical applications of a flexible coupling. Allowing only enough space between coils to partially close the gap during bending, the HELI-CAL Flexure can accept an angular misalignment of 20 degrees or more (and even up to 90 degrees in special u-joint applications).

**Optimized torque capacity**

The basic requirement of a flexible coupling is to transmit torque loads without permanent distortion or damage and without imposing undue bending or radial loads upon the driver or driven components. Once the working torque rating of a HELI-CAL Flexure coupling is established—based on misalignment and design criteria, material specifications and service factors supplied during the design process—its operational life is virtually unlimited.

**Configurable torsional stiffness**

Every flexible shaft coupling has some torsional flexibility. Torsional flexibility reflects the amount of twist in a system; torsional stiffness the degree of resistance against twist. The HELI-CAL Flexure can be configured (with thicker coils, for example), to provide the exact amount of torsional flexibility required in an application.

## Parallel

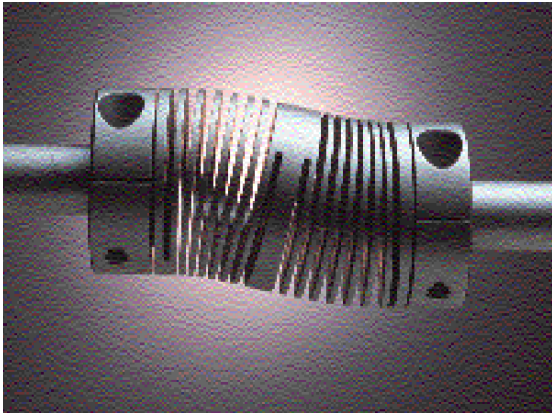

Parallel misalignment is the most difficult form of misalignment for couplings to compensate for. It can also be the most damaging to shafts, bearings and motors. The HELI-CAL Flexure, through lateral displacement, transforms an application's parallel misalignment problems into angular displacement within the coupling. The center coils of the HELI-CAL Flexure can become an intermediate shaft that can allow 10, 20 or 30 thousandths of an inch of parallel offset or more.

### Smooth bearing loads

Bearing loads are primarily generated by a coupling's natural resistance to bending, and can be very destructive forces to an apparatus and its rotational components. The HELI-CAL Flexure maintains a very constant radial and bending load at all points of rotation, providing exceptionally uniform bearing loads.

### Constant velocity

In a rotating system, constant velocity refers to the relative rotational speed of the input and output shafts. In a constant velocity system the driven end of the coupling turns exactly the same rate as the driver end. When operating under a uniform load the HELI-CAL Flexure design provides constant velocity and alleviates:

## Skewed

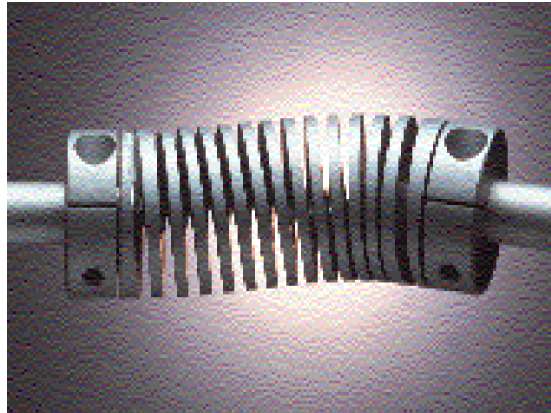

When shafts are not in the same plane (skewed), the HELI-CAL Flexure's abilities to compensate are the same as with either parallel or angular misalignment - but in the third dimension. A Flexure designed with more coils in a series can compensate for as much three-dimensional misalignment as your application requires.

- ◆ Backlash: the HELI-CAL Flexure has zero backlash, because of its one-piece construction.
- ◆ Angular misalignment, which can induce large fluctuations in rotational velocity in many coupling designs, is corrected by the HELI-CAL Flexure's constant spring rate at all points of rotation.
- ◆ Torsional variations, which can induce differences in hub-to-hub velocity when subjected to dynamic loading, are minimal in steady-state applications of the HELI-CAL Flexure.
- ◆ Concentricity, when there is a lack of it—particularly in the case of couplings with backlash or where production variation is difficult to prevent—the HELI-CAL Flexure's one-piece integrity minimizes sinusoidal variations.

Continued -



This sampling of “standard” HELI-CAL Flexure couplings and specialized u-joints illustrates the variety of materials, coil configurations, bore diameters and attachment methods available to you.

No matter what its size or shape, the HELI-CAL Flexure design assures performance, reliability, quality and versatility, arguably unmatched in the coupling industry.

### Adaptable Operating Speeds

The ability to adapt to high— and low—speed applications is another inherent benefit of the HELI-CAL Flexure’s design. The Flexure transmits motion throughout its length and cross section in a continuous helix from end to end. Torsional loading tends to make the HELI-CAL Flexure draw toward its centerline, reducing the chance of whipping action normally associated with rotating components. Consequently, vibrations are kept to a minimum at all rotating points.

### Axial Compensation

Axial movement is inherent in any rotating componentry, such as the rotor assembly in a motor. Through compression/extension, the HELI-CAL Flexure absorbs and compensates for axial movement or end play. The curved-beam structure of the HELI-CAL Flexure operates naturally in this axial compensation mode, and special designs can accommodate for even large displacement applications. 

### HELI-CAL Flexure, Basic Product Summary







Refer to the summary chart on the next page to get an idea as to which coupling series most closely fits your application needs. You’ll then be able to find the appropriate coupling by following the series column down to the page number. If you do not see the coupling you need in these pages, let us know. Our engineers can create special Flexure designs to meet your particular performance demands.

The charts on the following pages highlight features and technical data for each of the standard HELI-CAL coupling series.

Information covered by each chart includes:

- ◆ Dimensional data
- ◆ Special notes
- ◆ Performance data
- ◆ Ordering information

**HELI-CAL Flexure, Basic Product Summary**

<b>A Series</b>	<b>H Series</b>	<b>DS Series</b>	<b>MC Series</b>		<b>W Series</b>	
aluminum 7075-T6	stainless steel 17-4PH	aluminum 7075-T6	aluminum 7075-T6	stainless steel 17-4PH	aluminum 7075-T6	stainless steel 17-4PH
						
<b>Description</b>						
General purpose, light to medium duty. An economical, maintenance free coupling, used in a variety of applications. Helical's most popular coupling.	Stainless steel version of "A" series, with higher torque capacity and torsional stiffness. Increased fatigue resistance.	Low inertia, high performance, aluminum coupling, using Helical double start technology. Torsionally stiffer and higher torque capacity than the "A" series. Lighter with lower inertia than the "H" series.	A general purpose aluminum coupling, used where more parallel misalignment is required. Has a large range of shaft sizes, with optional keyways.	Stainless steel version of "MCA(C)" series, with higher torque capacity and torsional stiffness. Increased fatigue resistance.	Metric dimensioned coupling, with metric fasteners. A light to medium duty coupling for those preferring to work strictly in the metric system. A general purpose coupling.	Stainless steel version of the "WA(C)" series, with higher torque capacity and torsional stiffness. Increased fatigue resistance with all metric dimensions and fasteners.
<b>Typical applications</b>						
Used for encoder/resolver applications, low torque pump, lead screw and various other applications.	For situations requiring a heavy duty coupling such as pumps, lead screws, and positioning systems; also for process equipment in industrial situations. Anywhere a rugged, tough, long-lasting coupling is needed.	For high speed motion control systems, where fast response time is important. E.g., lead and ball screws, encoders/resolvers, and anywhere high torsional stiffness is required.	Good for encoder/resolver applications, moderate torque pump, lead screw, and various other applications.	Good for pump, conveyor systems, and industrial processing equipment, where absolute reliability is required. Anywhere a rugged, tough, long-lasting coupling is needed.	Used for encoder/resolver applications, low torque pump, lead screw and various other applications.	For situations requiring a heavy duty coupling, for pump, lead screws, and positioning systems. Also for process equipment in industrial situations. Anywhere a rugged, tough, long-lasting coupling is needed.
<b>Misalignment compensation</b>						
5° angular, .010 inch parallel offset, .010 inch axial motion	5° angular, .010 inch parallel offset, .010 inch axial motion	3° angular, .010 inch parallel offset, .008 inch axial motion	5° angular, .030 inch parallel offset, .010 inch axial motion	5° angular, .030 inch parallel offset, .010 inch axial motion	5° angular, .25mm parallel offset, .25mm axial motion	5° angular, .25mm parallel offset, .25mm axial motion
<b>Torque range</b>						
1.2-51 lbin	2.4-100 lbin	14-190 lbin	26-233 lbin	51-392 lbin	.71-20 Nm	1.4-39 Nm
<b>Standard bores</b>						
0.059-0.750 inch 1.5-19.05mm	0.059-0.750 inch 1.5-19.05mm	0.188-0.750 inch 4.78-19.05mm	0.250-.875 inch 6.35-22.23mm	0.250-1.000 inch 6.35-25.40mm	3mm-12mm	3mm-12mm
<b>Attachment</b>						
Clamp or set screw	Clamp or set screw	Clamp	Clamp or set screw Keyways optional	Clamp or set screw Keyways optional	Clamp or set screw	Clamp or set screw
<b>Operating temperatures</b>						
Up to 200° F	Up to 600° F	Up to 200° F	Up to 200° F	Up to 600° F	Up to 100° C	Up to 300° C
<b>Speed (in wind-up direction)</b>						
10,000 rpm	10,000 rpm	10,000 rpm	3,600 rpm	3,600 rpm	10,000 rpm	10,000 rpm
<b>For more information, see page</b>						
10	10	12	14	14	16	16

Note: For PF Series see page 20.



A SERIES



H SERIES

**Features, A Series**

- Light to medium duty
- Non-magnetic
- Economical
- No maintenance

The A Series coupling meets performance demands over a wide range of applications, including drive systems for encoders, instrumentation, lead screws, small pumps, feed rollers and anywhere a light to medium duty, torsionally flexible coupling is required. Helical's most popular coupling.

**Features, H Series**

- High torque capacity
- High fatigue resistance
- Corrosion resistant steel (CRES)

The H Series coupling is ideal when high strength, excellent fatigue resistance and high torsional stiffness is called for in your application. The H Series' premium performance capability is designed for applications requiring a heavy-duty coupling, such as drive systems, small pumps and gear boxes.

**Shared Features of the A & H Series**

- ♦ No maintenance
- ♦ Shaft sizes from 3/32 to 3/4

An array of options, in a variety of diameter sizes, allows you to tailor the A or H Series to your specific applications. A and H Series options include set screw or integral clamp attachments and inch or metric bores.

**Attachment Methods**

**Integral Clamp / ACR & HCR**

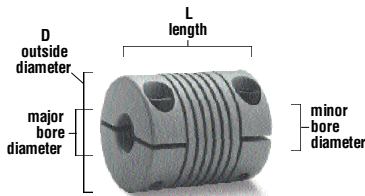

**Set Screw / AR & HR**  
(two each end @ 120°)

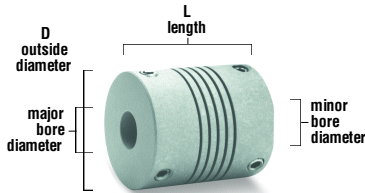

**Internal Configuration**

**Relief \***

Major and minor diameter shafts may enter flexure area during operation

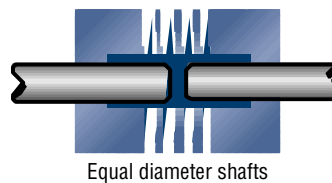
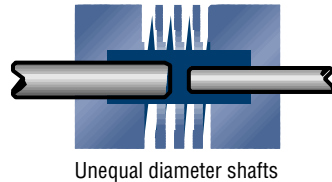

\* Dark areas indicate relief within the coupling interior

**How To Order**

Coupling part numbers consist of four sections. To determine the correct numbers/letters for each section of a specific coupling part number, please refer to the charts on the following pages.

**Example**

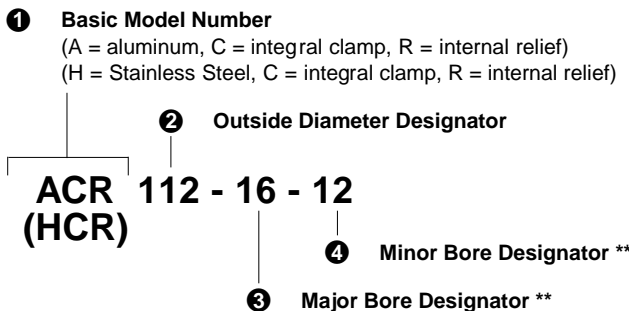

\*\* Refer to "Standard Bore Diameters" section of chart

- Basic Model Number:** Choose material and attachment method.  
**ACR** = Aluminum, Integral Clamp  
**AR** = Aluminum, Set Screw  
**HCR** = Stainless Steel, Integral Clamp  
**HR** = Stainless Steel, Set Screw
- Outside Diameter Designator:** This three-digit number represents the coupling outside diameter. Based on the Performance Data in the middle of the chart, select the Outside Diameter Designator by moving left to the appropriate diameter.
- Major Bore Designator:** The larger of the two bores, its diameter is expressed in either 32nds of an inch (-8 equals 1/4 inch) or in millimeters (6mm). Please review your selection to determine if both bores can be made in the size coupling you have selected in ②. It is important that the larger bore be stated first.
- Minor Bore Designator:** The smaller of the two bores is expressed the same as the Major Bore Designator. Either bore can be inch or mm.

## HELICAL A SERIES Aluminum, Technical Data

1			2		3 & 4		Attachment Screw						
Basic Model Number			Dimensional Information		Standard Bore Diameters		Performance Data		Inertia	Screw Size		Seating Torque	Center Line
Integral Clamp Attachment	Set Screw Attachment	Outside Diameter Designator	D Outside Diameter (in.)	L Length (in.)	(+.002in/- .000in) Note 6 Size in. & (mm)	Bore Designator (1/32 in.)	Momentary Dynamic Torque Note 2 (lbin)	Torsional Rate (degree/lbin)	$\times 10^{-5}$ (lbinsec <sup>2</sup> ) Note 7	Integral Clamp Note 4	Set Screw Note 4	(lbin)	(in.)
ACR	AR	050	1/2	0.75	0.094 (2.39)	3	3.7	0.98	0.11	1-72		4.0	.09
				0.50	0.125 (3.18)	4	3.5	1.3	0.069		2-56	1.3	.06
ACR	AR	062	5/8	0.80	0.125 (3.18)	4	7.1	0.51	0.28	2-56		4.5	.10
				0.62	0.157 (3.99)	5	6.7	0.66	0.21		4-40	4.3	.07
ACR	AR	075	3/4	0.90	0.125 (3.18)	4	10	0.29	0.66	4-40		10	.12
				0.75	0.157 (3.99)	5	10	0.36	0.54		6-32	8.0	.09
ACR	AR	087	7/8	1.06	0.125 (3.18)	4	19	0.20	1.5	6-32		19	.15
				0.87	0.157 (3.99)	5	17	0.28	1.2		6-32	8.0	.10
ACR	AR	100	1	1.25	0.188 (4.78)	6	27	0.17	3.0	6-32		19	.15
				1.00	0.250 (6.35)	8	24	0.24	2.3		10-24	25	.15
ACR	AR	112	1 1/8	1.50	0.313 (7.95)	10	43	0.094	5.6	6-32		19	.15
				1.12	0.375 (9.53)	12	40	0.12	4.1		10-24	25	.14
ACR	AR	125	1 1/4	1.62	0.375 (9.53)	12	48	0.11	9.3	10-24		50	.22
				1.25	0.500 (12.70)	16*	39	0.20	6.9		1/4-20	65	.16

\* Refer to note 8

### Notes

- Shaft misalignments:
  - Angular 5 degrees
  - Parallel Offset .010 in.
  - (.020 in. T.I.R.)
  - Axial Motion  $\pm$  .010 in.
- Dynamic torque ratings are momentary values. For non-reversing applications, divide by 2. Divide by 4 for reversing applications. Should the torque ratings be marginal for your application, contact us for analysis.
- Material : 7075-T6 aluminum alloy used for ACR / AR series. Finish: clear anodize  
or Material: 17-4 PH high-strength stainless steel used for HCR / HR series. Finish: natural
- Metric fasteners available on request.
- Manufacturing dimensional tolerances unless otherwise specified are:
  - fraction  $\pm$  1/64
  - x.xx  $\pm$  .01 in.
- Please refer to page 18 for other available bore dimensions.
- Inertia is based on smallest standard bore diameter.
- With integral clamp attachments only, this bore size requires an operating clearance diameter greater than coupling outside diameter.

## HELICAL H SERIES Stainless Steel, Technical Data

1			2		3 & 4		Attachment Screw						
Basic Model Number			Dimensional Information		Standard Bore Diameters		Performance Data		Inertia	Screw Size		Seating Torque	Center Line
Integral Clamp Attachment	Set Screw Attachment	Outside Diameter Designator	D Outside Diameter (in.)	L Length (in.)	(+.002in/- .000in) Note 6 Size in. & (mm)	Bore Designator (1/32 in.)	Momentary Dynamic Torque Note 2 (lbin)	Torsional Rate (degree/lbin)	$\times 10^{-5}$ (lbinsec <sup>2</sup> ) Note 7	Integral Clamp Note 4	Set Screw Note 4	(lbin)	(in.)
HCR	HR	050	1/2	0.75	0.094 (2.39)	3	7.5	0.36	0.31	1-72		4.0	.09
				0.50	0.125 (3.18)	4	7.0	0.48	0.19		2-56	1.3	.06
HCR	HR	062	5/8	0.80	0.125 (3.18)	4	14	0.19	0.78	2-56		4.5	.10
				0.62	0.157 (3.99)	5	13	0.24	0.58		4-40	4.3	.07
HCR	HR	075	3/4	0.90	0.125 (3.18)	4	21	0.11	1.8	4-40		10	.12
				0.75	0.157 (3.99)	5	20	0.13	1.5		6-32	8.0	.09
HCR	HR	087	7/8	1.06	0.188 (4.78)	6	37	0.072	4.1	6-32		19	.15
				0.87	0.250 (6.35)	8	34	0.10	3.3		6-32	8.0	.10
HCR	HR	100	1	1.25	0.313 (7.95)	10	52	0.062	8.3	6-32		19	.15
				1.00	0.375 (9.53)	12	47	0.086	6.5		10-32	25	.15
HCR	HR	112	1 1/8	1.50	0.250 (6.35)	8	83	0.035	15.6	6-32		19	.15
				1.12	0.313 (7.95)	10	78	0.045	11.3		10-32	25	.14
HCR	HR	125	1 1/4	1.62	0.375 (9.53)	12	94	0.041	26.0	10-32		56	.22
				1.25	0.500 (12.70)	16*	77	0.071	19.4		1/4-28	65	.16

\* Refer to note 8

Features



DS SERIES

- High torsional stiffness
- Low radial loads
- Parallel misalignment capability
- Low inertia

The DS Series was designed for today's high performance motion control systems. This Series incorporates two helical beams in each of two separate HELI-CAL Flexures, combining greater end-to-end rotational accuracy with radial flexibility in one design. Available only

with integral clamp attachments, the DS Series provides the high torsional stiffness and low inertia necessary for positioning devices, servo motors and lead screws.

The DS Series also provides you with substantial .010-inch parallel offset capability, reducing the need for high-precision alignment during assembly operations. It's your ticket to greater system accuracy and reliability. Available only in 7075-T6 aluminum.

Attachment Methods

Integral Clamp / DSAC

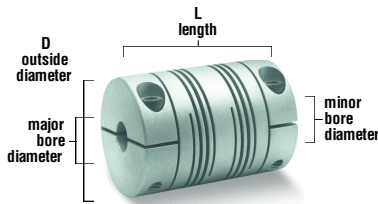

Internal Configuration

Relief \*

Major and minor diameter shafts may enter flexure area during operation

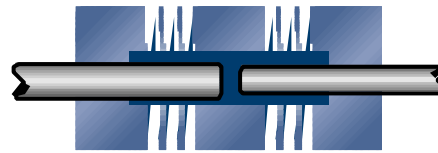

Unequal diameter shafts

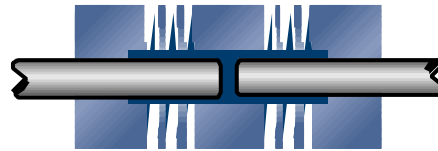

Equal diameter shafts

\* Dark areas indicate relief within the coupling interior

How To Order

Coupling part numbers consist of four sections. To determine the correct numbers/letters for each section of a specific coupling part number, please refer to the charts on the following pages.

Example

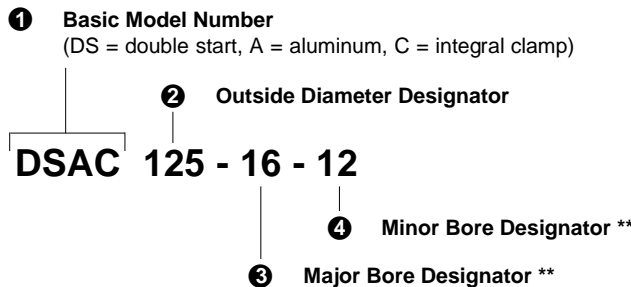

- Basic Model Number:**  
**DSAC** = Double start flexure, Aluminum and Integral Clamp
- Outside Diameter Designator:** This three-digit number represents the coupling outside diameter. Based on the Performance Data in the middle of the chart, select the Outside Diameter Designator by moving left to the appropriate diameter.
- Major Bore Designator:** The larger of the two bores, its diameter is expressed in either 32nds of an inch (-8 equals 1/4 inch) or in millimeters (6mm). Please review your selection to determine if both bores can be made in the size coupling you have selected in **2**. It is important that the larger bore be stated first.
- Minor Bore Designator:** The smaller of the two bores is expressed the same as the Major Bore Designator. Either bore can be inch or mm.

\*\* Refer to "Standard Bore Diameters" section of chart

## HELICAL DS SERIES, Aluminum, Technical Data

Basic Model Number		Dimensional Information		Standard Bore Diameters		Performance Data		Inertia	Screw Size	Seating Torque	Center Line
Integral Clamp Attachment	Outside Diameter Designator	D Outside Diameter (in.)	L Length (in.)	Size in. & (mm)	Bore Designator (1/32 in.)	Momentary Dynamic Torque Note 2 (lbin)	Torsional Rate (degree/lbin)	x 10 <sup>-4</sup> (lbinsec <sup>2</sup> ) Note 7	Integral Clamp Note 4	(lbin)	(in.)
DSAC	<b>075</b>	3/4	1.25	(+.002in /-.000in) Note 6 0.188 (4.78) 0.250 (6.35)	6 8	14 12	0.30 0.40	0.091	4-40	10	.12
DSAC	<b>100</b>	1	1.50	0.250 (6.35) 0.313 (7.95) 0.375 (9.53)	8 10 12	31 29 25	0.13 0.16 0.19	0.35	6-32	19	.15
DSAC	<b>125</b>	1 1/4	1.75	0.313 (7.95) 0.375 (9.53) 0.500(12.70) 0.625(15.88)	10 12 16* 20*	61 58 47 35	0.062 0.080 0.12 0.19	0.98	10-24	50	.22
DSAC	<b>150</b>	1 1/2	2.25	0.375 (9.53) 0.500(12.70) 0.625(15.88)	12 16 20	130 115 94	0.030 0.042 0.062	2.7	10-24	50	.22
DSAC	<b>200</b>	2	2.50	0.500(12.70) 0.625(15.88) 0.750(19.05)	16 20 24	234 215 190	0.016 0.020 0.026	9.5	1/4-20	120	.26

\* Refer to note 8

### Notes

#### 1. Shaft misalignments:

Angular	3 degrees
Parallel Offset	.010 in. (.020 in. T.I.R.)
Axial Motion	± .008 in.

2. Dynamic torque ratings are momentary values. For non-reversing applications, divide by 2. Divide by 4 for reversing applications. Should the torque ratings

be marginal for your application, contact us for analysis.

3. Material : 7075-T6 aluminum alloy  
Finish: clear anodize

4. Metric fasteners available on request.

5. Manufacturing dimensional tolerances unless otherwise specified are:

fraction	± 1/64
x.xx	± .01 in.

6. Please refer to page 18 for other available bore dimensions.

7. Inertia is based on smallest standard bore diameter.

8. This bore size requires an operating clearance diameter greater than coupling outside diameter.

Features



MC SERIES  
(aluminum shown)

- Industrial motor shaft couplings
- Large parallel misalignment capacity
- High torque capacity
- Large shaft diameters
- Keyways available

This versatile series of couplings provides you with a full range of torque capacities and bore sizes, all with 1/32-inch parallel misalignment capability. These couplings attach to shafts with your choice of integral

clamps or set screws. Combine this with optional keyways and the MC Series is tailor-made for your application.

From medium-duty (aluminum) to heavy-duty (stainless steel), this series provides solutions for a wide range of applications. From pumps and lead screws to conveyors, chances are an MC Series coupling will fit your needs. Available in 7075-T6 aluminum alloy or 17-4 PH corrosion resistant steel (CRES).

Attachment Methods

Integral Clamp / MCAC & MC7C

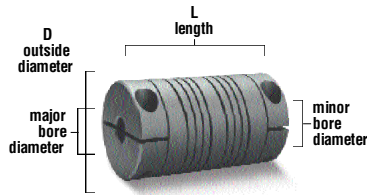

Set Screw / MCA & MC7  
(two each end @ 120°)

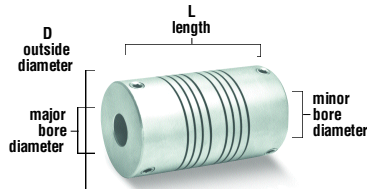

Internal Configuration

Relief \*

Major and minor diameter shafts may enter flexure area during operation

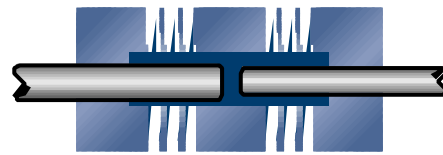

Unequal diameter shafts

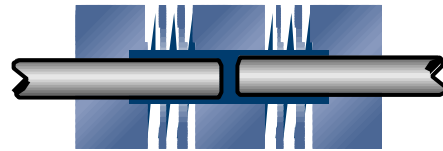

Equal diameter shafts

\* Dark areas indicate relief within the coupling interior

How To Order

Coupling part numbers consist of four sections. To determine the correct numbers/letters for each section of a specific coupling part number, please refer to the charts on the following pages.

Example

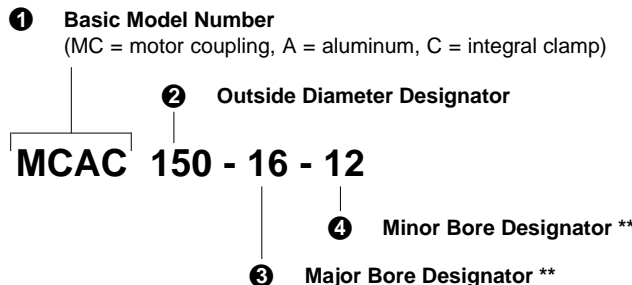

\*\* Refer to "Standard Bore Diameters" section of chart

- 1 Basic Model Number:**  
 Choose material and attachment method.  
**MCAC** = Aluminum, Integral Clamp  
**MCA** = Aluminum, Set Screw  
**MC7C** = Stainless Steel, Integral Clamp  
**MC7** = Stainless Steel, Set Screw
- 2 Outside Diameter Designator:** This three-digit number represents the coupling outside diameter. Based on the Performance Data in the middle of the chart, select the Outside Diameter Designator by moving left to the appropriate diameter.
- 3 Major Bore Designator:** The larger of the two bores, its diameter is expressed in either 32nds of an inch (-8 equals 1/4 inch) or in millimeters (6mm). Please review your selection to determine if both bores can be made in the size coupling you have selected in 2. It is important that the larger bore be stated first.
- 4 Minor Bore Designator:** The smaller of the two bores is expressed the same as the Major Bore Designator. Either bore can be inch or mm.

## HELICAL MC SERIES, Aluminum, Technical Data

1			2		3 & 4			Attachment Screw					
Basic Model Number			Dimensional Information		Standard Bore Diameters		Performance Data		Inertia	Screw Size		Seating Torque	Center Line
Integral Clamp Attachment	Set Screw Attachment	Outside Diameter Designator	D Outside Diameter (in.)	L Length (in.)	(+.002in/- .000in) Note 6 Size in. & (mm)	Note 6 Bore Designator (1/32 in.)	Momentary Dynamic Torque Note 2 (lbin)	Torsional Rate (degree/lbin)	$\times 10^{-4}$ (lbinsec <sup>2</sup> ) Note 7	Integral Clamp Note 4	Set Screw Note 4	(lbin)	(in.)
MCAC		100	1	1.75	0.250 (6.35) 0.313 (7.95) 0.375 (9.53)	8 10 12	26 23 20	0.270 0.370 0.530	0.41	6-32		19	.15
	MCA										10-24		
MCAC		125	1 1/4	2.37	0.313 (7.95) 0.375 (9.53) 0.500 (12.70)	10 12 16*	51 47 38	0.130 0.170 0.300	1.3	10-24		50	.22
	MCA										1/4-20		
MCAC		150	1 1/2	2.62	0.375 (9.53) 0.500 (12.70)	12 16	100 88	0.065 0.100	3.1	10-24		50	.22
	MCA										1/4-20		
MCAC		200	2	3.00	0.500 (12.70) 0.625 (15.88)	16 20	178 164	0.035 0.049	11.4	1/4-20		120	.26
	MCA										1/4-20		
MCAC		225	2 1/4	3.50	0.625 (15.88) 0.750 (19.05) 0.875 (22.23)	20 24 28	286 262 233	0.024 0.032 0.044	21.5	1/4-20		120	.26
	MCA										1/4-20		

\* Refer to note 8

## HELICAL MC SERIES, Stainless Steel, Technical Data

1			2		3 & 4			Attachment Screw					
Basic Model Number			Dimensional Information		Standard Bore Diameters		Performance Data		Inertia	Screw Size		Seating Torque	Center Line
Integral Clamp Attachment	Set Screw Attachment	Outside Diameter Designator	D Outside Diameter (in.)	L Length (in.)	(+.002in/- .000in) Note 6 Size in. & (mm)	Note 6 Bore Designator (1/32 in.)	Momentary Dynamic Torque Note 2 (lbin)	Torsional Rate (degree/lbin)	$\times 10^{-4}$ (lbinsec <sup>2</sup> ) Note 7	Integral Clamp Note 4	Set Screw Note 4	(lbin)	(in.)
MC7C		100	1	1.75	0.250 (6.35) 0.313 (7.95) 0.375 (9.53)	8 10 12	51 46 40	0.098 0.140 0.190	1.1	6-32		19	.15
	MC7										10-32		
MC7C		125	1 1/4	2.37	0.313 (7.95) 0.375 (9.53) 0.500 (12.70) 0.625 (15.88)	10 12 16* 20*	98 91 74 54	0.048 0.062 0.110 0.210	3.8	10-32		56	.22
	MC7										1/4-28		
MC7C		150	1 1/2	2.62	0.375 (9.53) 0.500 (12.70) 0.625 (15.88)	12 16 20	194 170 140	0.024 0.037 0.060	8.7	10-32		56	.22
	MC7										1/4-28		
MC7C		200	2	3.00	0.500 (12.70) 0.625 (15.88) 0.750 (19.05)	16 20 24	347 319 282	0.013 0.018 0.025	31.9	1/4-28		135	.26
	MC7										1/4-28		
MC7C		225	2 1/4	3.50	0.625 (15.88) 0.750 (19.05) 0.875 (22.23) 1.000 (25.40)	20 24 28 32	556 510 454 392	0.009 0.012 0.016 0.023	60.0	1/4-28		135	.26
	MC7										1/4-28		

\* Refer to note 8

### Notes

- Shaft misalignments:
  - Angular 5 degrees
  - Parallel Offset .030 in. (.060 in. T.I.R.)
  - Axial Motion  $\pm .010$  in.
- Dynamic torque ratings are momentary values. For non-reversing applications, divide by 2. Divide by 4 for reversing applications. Should the torque ratings be marginal for your application, contact us for analysis.
- Material : 7075-T6 aluminum alloy  
Finish: clear anodize  
or Material: 17-4 PH high-strength stainless steel.  
Finish: natural
- Metric fasteners available on request.
- Manufacturing dimensional tolerances unless otherwise specified are:
  - fraction  $\pm 1/64$
  - x.xx  $\pm .01$  in.
- Please refer to page 19 for other available bore dimensions.
- Inertia is based on smallest standard bore diameter.
- With integral clamp attachments only, this bore size requires an operating clearance diameter greater than coupling outside diameter.
- Inch and metric keyways available.

Features

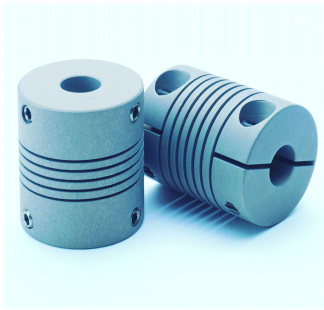

W SERIES  
(aluminum shown)

- Metric dimensions and fasteners
- Available in 7075-T6 aluminum alloy or 17-4 PH corrosion-resistant steel
- General purpose

If you are working in the *metric* world, the W Series is for you. It combines the best features of the A Series and the H Series, with the convenience of metric dimensions

and fasteners for your metric based designs. The W Series can be used in a wide range of applications from driving components with light torque requirements, such as encoders and tachometers (aluminum), to lead screws and pumps requiring greater torque (stainless steel).

Attachment Methods

Integral Clamp / WAC & W7C

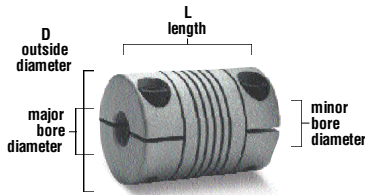

Set Screw / WA & W7  
(two each end @ 120°)

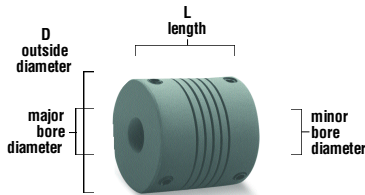

Internal Configuration

Relief \*

Major and minor diameter shafts may enter flexure area during operation

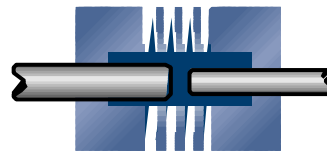

Unequal diameter shafts

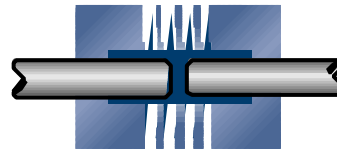

Equal diameter shafts

\* Dark areas indicate relief within the coupling interior

How To Order

Coupling part numbers consist of four sections. To determine the correct numbers/letters for each section of a specific coupling part number, please refer to the charts on the following pages.

Example

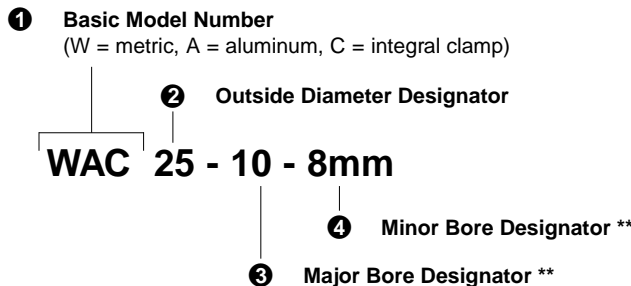

\*\* Refer to "Standard Bore Diameters" section of chart

- Basic Model Number:** Choose material and attachment method.

**WAC** = Aluminum, Integral Clamp  
**WA** = Aluminum, Set Screw  
**W7C** = Stainless Steel, Integral Clamp  
**W7** = Stainless Steel, Set Screw
- Outside Diameter Designator:** This two-digit number represents the coupling outside diameter. Based on the Performance Data in the middle of the chart, select the Outside Diameter Designator by moving left to the appropriate diameter.
- Major Bore Designator:** The larger of the two bores, its diameter is expressed in either millimeters (6mm) or in 32nds of an inch (-8 equals 1/4 inch). Please review your selection to determine if both bores can be made in the size coupling you have selected in ②. It is important that the larger bore be stated first.
- Minor Bore Designator:** The smaller of the two bores is expressed the same as the Major Bore Designator. Either bore can be mm or inch. Please specify mm when metric.

## HELICAL W SERIES, Aluminum, Technical Data

①			②		③ & ④				Attachment Screw				
Basic Model Number			Dimensional Information		Standard Bore Diameters		Performance Data		Inertia	Screw Size		Seating Torque	Center Line
Integral Clamp Attachment	Set Screw Attachment	Outside Diameter Designator	D Outside Diameter	L Length (mm)	(+0.05mm / -0.00mm) Note 5		Momentary Dynamic Torque Note 2 (Nm)	Torsional Rate (degree/Nm)	$\times 10^{-4}$ (kgcmsec <sup>2</sup> ) Note 6	Integral Clamp	Set Screw	(Nm)	(mm)
WAC	WA	15	15mm	22	3.00	3mm	0.71	5.1	0.028	M2x.4		0.5	2.5
				20	4.00 5.00	4mm 5mm	0.66 0.59	7.2 10.0	0.025			M3x.5	1.0
WAC	WA	20	20mm	28	4.00	4mm	1.3	2.7	0.11	M3x.5		2.0	3.8
				20	5.00 6.00	5mm 6mm	1.2 1.1	3.5 4.5	0.079			M3x.5	1.0
WAC	WA	25	25mm	30	6.00	6mm	2.9	1.5	0.30	M3x.5		2.0	3.8
				24	7.00 8.00 9.00 10.00	7mm 8mm 9mm 10mm	2.8 2.6 2.4 2.2	1.8 2.2 2.8 3.5	0.24			M4x.7	2.1
WAC	WA	30	30mm	38	9.00	9mm	4.9	1.1	0.78	M4x.7		4.7	5.0
				30	10.00 11.00 12.00	10mm 11mm 12mm	4.6 4.3 4.0	1.3 1.6 1.9	0.60			M5x.8	4.7
WAC	WA	40	40mm	50	12.00	12mm	12	0.45	3.3	M5x.8		9.5	5.8
				50	13.00 14.00 15.00 16.00	13mm 14mm 15mm 16mm	11 11 10 9.7	0.51 0.59 0.67 0.78	3.3			M6x1	7.7
WAC	WA	50	50mm	54	14.00	14mm	19	0.25	7.6	M6x1		16	6.7
				54	16.00 18.00 19.00 20.00	16mm 18mm 19mm 20mm	18 17 16 15	0.31 0.39 0.43 0.49	7.6			M6x1	7.7

### Notes

- Shaft misalignments:
  - Angular 5 degrees
  - Parallel Offset .25 mm  
(.50 mm T.I.R.)
  - Axial Motion  $\pm$  .25 mm
- Dynamic torque ratings are momentary values. For non-reversing applications, divide by 2. Divide by 4 for reversing applications. Should the torque ratings be marginal for your application, contact us for analysis.
- Material : 7075-T6 aluminum alloy  
Finish: clear anodize  
or Material: 17-4 PH high-strength stainless steel.  
Finish: natural
- Manufacturing dimensional tolerances unless otherwise specified are:
  - x  $\pm$  .5 mm
  - x.x  $\pm$  .25 mm
- Please refer to page 19 for other available bore dimensions.
- Inertia is based on smallest standard bore diameter.
- Keyways available on the 40 mm and 50 mm OD only.

## HELICAL W SERIES, Stainless Steel, Technical Data

①			②		③ & ④				Attachment Screw				
Basic Model Number			Dimensional Information		Standard Bore Diameters		Performance Data		Inertia	Screw Size		Seating Torque	Center Line
Integral Clamp Attachment	Set Screw Attachment	Outside Diameter Designator	D Outside Diameter	L Length (mm)	(+0.05mm / -0.00mm) Note 5		Momentary Dynamic Torque Note 2 (Nm)	Torsional Rate (degree/Nm)	$\times 10^{-4}$ (kgcmsec <sup>2</sup> ) Note 6	Integral Clamp	Set Screw	(Nm)	(mm)
W7C	W7	15	15mm	22	3.00	3mm	1.4	1.9	0.078	M2x.4		0.5	2.5
				20	4.00 5.00	4mm 5mm	1.3 1.2	2.6 3.7	0.070			M3x.5	1.0
W7C	W7	20	20mm	28	4.00	4mm	2.6	0.99	0.32	M3x.5		2.0	3.8
				20	5.00 6.00	5mm 6mm	2.5 2.3	1.3 1.6	0.22			M3x.5	1.0
W7C	W7	25	25mm	30	6.00	6mm	5.7	0.54	0.84	M3x.5		2.0	3.8
				24	7.00 8.00 9.00 10.00	7mm 8mm 9mm 10mm	5.5 5.1 4.7 4.3	0.66 0.82 1.0 1.3	0.66			M4x.7	2.1
W7C	W7	30	30mm	38	9.00	9mm	9.5	0.40	2.2	M4x.7		4.7	5.0
				30	10.00 11.00 12.00	10mm 11mm 12mm	8.9 8.3 7.7	0.48 0.58 0.70	1.7			M5x.8	4.7
W7C	W7	40	40mm	50	12.00	12mm	23	0.16	9.2	M5x.8		9.5	5.8
				50	13.00 14.00 15.00 16.00	13mm 14mm 15mm 16mm	22 21 20 19	0.19 0.21 0.24 0.28	9.2			M6x1	7.7
W7C	W7	50	50mm	54	14.00	14mm	37	0.092	21	M6x1		16	6.7
				54	16.00 18.00 19.00 20.00	16mm 18mm 19mm 20mm	35 33 31 30	0.11 0.14 0.16 0.18	21			M6x1	7.7

**HELICAL A and H SERIES / pages 10 - 11**

Basic Model Number		Outside Diameter		Special Bore Diameters			
Integral Clamp Attachment	Set Screw Attachment	Outside Diameter Designator	D Outside Diameter (in.)	With Relief		Restricted Bore Configurations*	
				Minimum Size in. & (mm)	Maximum Size in. & (mm)	Maximum Size in. & (mm)	Bore Depth in. & (mm)
ACR/HCR		<b>050</b>	1/2	0.090 (2.29)	0.125 (3.18)	0.236 (6.00)	0.19 (4.83)
	AR/HR			0.090 (2.29)	0.125 (3.18)	0.315 (8.00)	0.12 (3.05)
ACR/HCR		<b>062</b>	5/8	0.090 (2.29)	0.197 (5.00)	0.325 (8.26)	0.20 (5.08)
	AR/HR			0.090 (2.29)	0.197 (5.00)	0.375 (9.53)	0.14 (3.56)
ACR/HCR		<b>075</b>	3/4	0.118 (3.00)	0.250 (6.35)	0.390 (9.90)	0.25 (6.35)
	AR/HR			0.118 (3.00)	0.250 (6.35)	0.512 (13.00)	0.18 (4.57)
ACR/HCR		<b>087</b>	7/8	0.138 (3.50)	0.315 (8.00)	0.444 (11.27)	0.31 (7.87)
	AR/HR			0.118 (3.00)	0.315 (8.00)	0.630 (16.00)	0.20 (5.08)
ACR/HCR		<b>100</b>	1	0.156 (3.96)	0.375 (9.53)	0.563 (14.31)	0.31 (7.87)
	AR/HR			0.156 (3.96)	0.375 (9.53)	0.630 (16.00)	0.26 (6.60)
ACR/HCR		<b>112</b>	1 1/8	0.188 (4.78)	0.512 (13.00)	0.684 (17.38)	0.45 (11.43)
	AR/HR			0.188 (4.78)	0.512 (13.00)	0.630 (16.00)	0.27 (6.86)
ACR/HCR		<b>125</b>	1 1/4	0.313 (7.94)	0.625 (15.88)	0.669 (17.00)	0.51 (12.95)
	AR/HR			0.313 (7.94)	0.625 (15.88)	0.750 (19.05)	0.32 (8.13)

**HELICAL DS SERIES / pages 12 - 13**

Basic Model Number		Outside Diameter		Special Bore Diameters			
Integral Clamp Attachment	Outside Diameter Designator	D Outside Diameter (in.)	With Relief		Restricted Bore Configurations*		
			Minimum Size in. & (mm)	Maximum Size in. & (mm)	Maximum Size in. & (mm)	Bore Depth in. & (mm)	
DSAC	<b>075</b>	3/4	0.188 (4.78)	0.250 (6.35)	0.390 (9.90)	0.25 (6.35)	
DSAC	<b>100</b>	1	0.250 (6.35)	0.394 (10.00)	0.563 (14.31)	0.38 (9.65)	
DSAC	<b>125</b>	1 1/4	0.313 (7.95)	0.630 (16.00)	0.668 (16.98)	0.44 (11.18)	
DSAC	<b>150</b>	1 1/2	0.375 (9.53)	0.630 (16.00)	0.908 (23.07)	0.57 (14.48)	
DSAC	<b>200</b>	2	0.500 (12.70)	0.750 (19.05)	1.280 (32.50)	0.68 (17.27)	

\*Restricted Bore Configuration

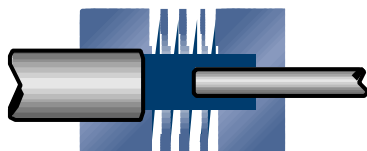

Unequal diameter shafts

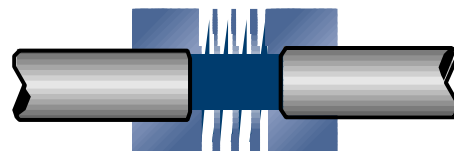

Equal diameter shafts

Basic Model Number				Outside Diameter		Special Bore Diameters			
Integral Clamp Attachment	Set Screw Attachment			Outside Diameter Designator	D Outside Diameter (in.)	With Relief		Restricted Bore Configurations*	
						Minimum Size in. & (mm)	Maximum Size in. & (mm)	Maximum Size in. & (mm)	Bore Depth in.. & (mm)
MC7C	MCAC	MC7	MCA	100	1	0.156 (3.96)	0.394 (10.00)	0.563 (14.30)	0.37 (9.40)
						0.156 (3.96)	0.394 (10.00)	0.563 (14.30)	
						0.156 (3.96)	0.394 (10.00)	0.630 (16.00)	
						0.156 (3.96)	0.394 (10.00)	0.630 (16.00)	
MC7C	MCAC	MC7	MCA	125	1 1/4	0.313 (7.95)	0.630 (16.00)	0.668 (16.98)	0.51 (12.95)
						0.313 (7.95)	0.512 (13.00)	0.668 (16.98)	
						0.313 (7.95)	0.630 (16.00)	0.750 (19.05)	
						0.313 (7.95)	0.512 (13.00)	0.750 (19.05)	
MC7C	MCAC	MC7	MCA	150	1 1/2	0.313 (7.95)	0.630 (16.00)	0.908 (23.07)	0.66 (16.76)
						0.313 (7.95)	0.512 (13.00)	0.908 (23.07)	
						0.313 (7.95)	0.630 (16.00)	1.000 (25.40)	
						0.313 (7.95)	0.512 (13.00)	1.000 (25.40)	
MC7C	MCAC	MC7	MCA	200	2	0.375 (9.53)	0.750 (19.05)	1.280 (32.50)	0.75 (19.05)
						0.375 (9.53)	0.630 (16.00)	1.280 (32.50)	
						0.375 (9.53)	0.750 (19.05)	1.500 (38.10)	
						0.375 (9.53)	0.630 (16.00)	1.500 (38.10)	
MC7C	MCAC	MC7	MCA	225	2 1/4	0.375 (9.53)	1.000 (25.40)	1.525 (38.73)	0.86 (21.84)
						0.375 (9.53)	0.875 (22.23)	1.525 (38.73)	
						0.375 (9.53)	1.000 (25.40)	1.750 (44.45)	
						0.375 (9.53)	0.875 (22.23)	1.750 (44.45)	

Basic Model Number		Outside Diameter		Special Bore Diameters			
Integral Clamp Attachment	Set Screw Attachment	Outside Diameter Designator	D Outside Diameter	With Relief		Restricted Bore Configurations*	
				Minimum Size mm	Maximum Size mm	Maximum Size mm	Bore Depth mm
W7C/WAC	W7/WA	15	15mm	3.00	5.00	7.30	6.00
				3.00	5.00	9.00	4.85
W7C/WAC	W7/WA	20	20mm	4.00	6.35	9.81	8.55
				4.00	6.35	14.00	4.85
W7C/WAC	W7/WA	25	25mm	6.00	10.00	14.56	8.55
				6.00	10.00	17.00	5.85
W7C/WAC	W7/WA	30	30mm	9.00	12.70	17.30	11.00
				9.00	12.70	20.00	6.85
W7C/WAC	W7/WA	40	40mm	12.00	16.00	24.80	15.50
				12.00	16.00	25.40	17.00
W7C/WAC	W7/WA	50	50mm	14.00	20.00	32.11	15.50
				14.00	20.00	38.10	17.00

**Notes**

- Bore sizes are placed into the part number with leading dashes after the basic model number. Standard bore dimensions are noted in 32nds of an inch, such as 8/32 or 3/32 in. The respective dash numbers would be -8 and -3. Any bore dimensions that are not an integer number of 32nds should be converted to their millimeter equivalent with "mm" after the numerical designation, e.g., .315 in = 8 mm.
- When specifying part numbers, metric bore diameters are specified without trailing zeros after the decimal point, e.g. .315 in. = 8.00 mm, but the bore designation is -

- 8mm. This is only for simplicity in ordering and does not affect the tolerances of the actual bore dimensions. Bore tolerances are specified on the *Engineering Proposal Form* at the end of the catalog.
- Manufacturing dimensional tolerances unless otherwise specified are:

fract	x.xx	x.xxx	angle
± 1/64	±.010	±.005	±2°

x	x.x	x.xx	angle
±.5mm	±.25mm	±.15mm	±2°

- A complete line of specialty OEM and end-user products is available; please refer to the *Engineering Proposal Form* and/or contact our Engineering Department.
- A chart showing our standard line of instrumentation couplings with precision bore tolerancing is available upon request.
- All parts are available with metric or inch fasteners to be compatible with the fastener system used in your designs.
- Bore diameters less than minimum listed may be possible for one bore only. Contact our Engineering Department.

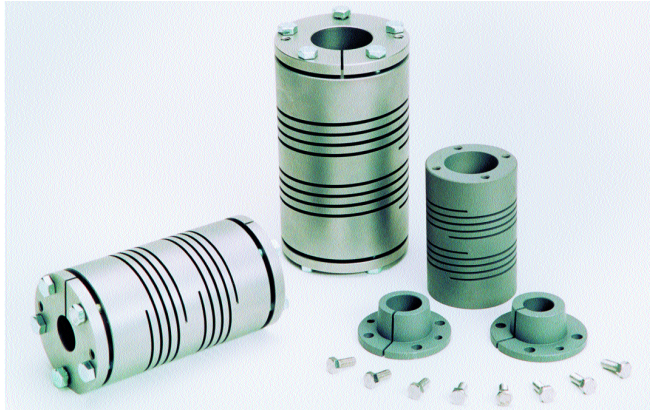

### Features

- No maintenance, lubrication or backlash.
- Available in aluminum and stainless steel with 2, 2.5 and 3 inch OD. Standard with quick change tapered bushings.
- Offered in inch or millimeter bore sizes up to 1 3/4 inch diameter.
- Torque capacities up to 1800 lbin.
- High torsional stiffness.
- Compensates for angular, parallel and axial misalignment.
- More torque for less money.

### Designer's Comments

The PowerFlex is essentially a very cost effective power transmission coupling. The benefits include no lubrication, no maintenance, no keyway requirements and zero backlash. Plus, the product provides more torque for less money than past Helical power transmission coupling offerings of the same size range.

Four key elements have been incorporated to create the PowerFlex: the HELI-CAL Flexure, the convenience of removable tapered bushings, high torque capacity, (up to 1800 lbin), and substantial misalignment capability.

Early on in the PowerFlex design process, it was recognized that the time tested and proven HELI-CAL Flexure should be utilized as the key coupling component.

After reviewing various combinations of coil thickness, number of coils, number of "starts" and flexure ID's, we arrived at a double start HELI-CAL Flexure configuration that accommodates sizable misalignments, and provides substantial torque capability, high torsional stiffness, and reasonable pricing. This represents value for the customer, which is always a key goal when we develop a new series of couplings.

This innovative design provides a flexible shaft coupling that can compensate for many operational variables, such as parallel offset and angular misalignment, present anytime two shafts are being attached. The PowerFlex's unique flexing element also accommodates axial motion between two shafts. The PowerFlex is available in anodized aluminum and stainless steel. Shaft sizes range from .50 to 1.75 inch diameter. Torque capacities range from 250 lbin for the 2.0 inch OD aluminum to 1800 lbin for the 3.0 inch OD stainless steel coupling.

The new couplings are configured with two flexing elements, each consisting of two curved beams spaced 180 degrees apart. Each curved beam is a spiral configuration that provides a beam long enough for good flexibility, but short enough to be torsionally stiff. This high torsional stiffness is exceedingly important in motion control systems where position accuracy is critical. Each double beam element can bend 2 degrees for a total of 4 degrees angular misalignment. The flexing elements are used in pairs to allow for parallel offset between two shafts.

The double beam configuration of the PowerFlex provides a stability that makes it well suited for high rotational speed applications up to 6,000 RPM. Since all the flexing for misalignment is taken up by the beams, (made from a single piece of material), the PowerFlex is perfect for those troublesome power transmission applications. The single piece flexing element makes this coupling essentially maintenance free. Besides featuring high torsional stiffness, the PowerFlex is also backlash free, making it particularly well suited for high torque motion control applications. The PowerFlex offers considerable savings in maintenance costs (there are none) in applications where lubrication access is restricted or near impossible.

A tapered bushing attachment provides a positive method to hold the coupling to the shaft. The bushing's taper angle is low enough to give good concentricity and torque transmission capacity yet high enough to release the bushings from the coupling easily. Installation is achieved by sliding the bushing up the shaft, and then placing the coupling into position. The bushing is tightened by progressively torquing the hex head screws to the specified torque in a star pattern. This star pattern tightening sequence is then repeated on the other end to complete the installation. Since the holding capacity of the tapered bushing is more than the maximum torque capacity of the coupling, keyways are not necessary.

Removal of the PowerFlex is accomplished by removing the hex head screws from both ends. The tapered bushings are released from the coupling by threading two of the hex head screws into the threaded holes of the tapered bushing flange. By tightening the hex head screws the tapered bushing is pulled from the coupling and the friction taper attachment is released.

Because we machine precision bore sizes into the tapered bushings, PowerFlex couplings can be assembled quickly to suit customer needs and delivered fast. Customers also may make coupling bore size changes themselves.

The PF Series PowerFlex is available in both inch and metric bore sizes in aluminum or stainless steel. Many sizes are available for immediate delivery. 

## HELICAL PF Series PowerFlex, Technical Data

STANDARD BORE DIAMETER +.002 / - .000 in (+0.05 / - .00 mm)			PERFORMANCE DATA			PART NUMBER	DIMENSIONAL INFORMATION				ATTACHMENT SCREW			WEIGHT  lb (kg)
Max w/RELIEF see note 1 in (mm)	Max w/STEP BORE see note 2 in (mm)	Min in (mm)	Momentary Dynamic Torque see note 3 lbin (Nm)	Torsional Stiffness lbin/rad (Nm/rad)	Parallel Offset in (mm)		OD in (mm)	L in (mm)	L1 in (mm)	B in (mm)	Size	Qty	Seating Torque lbin (Nm)	
.875 (22.00)	1.000 (25.00)	.500 (12.00)	250 (28)	2,150 (243)	.025 (.65)	PFA200	2.00 (50.8)	4.00 (101.6)	3.12 (79.2)	.82 (20.8)	M5	4	55 (6.2)	0.87 (.39)
			530 (60)	5,940 (672)	.025 (.65)								PFS200	65 (7.3)
1.125 (28.00)	1.375 (35.00)	.500 (12.00)	480 (55)	4,070 (460)	.030 (.75)	PFA250	2.50 (63.5)	4.75 (120.7)	3.70 (94.0)	1.00 (25.4)	M6	5	90 (10)	1.68 (.76)
			1,025 (115)	11,270 (1,273)	.030 (.75)								PFS250	110 (12)
1.375 (35.00)	1.750 (44.00)	.625 (16.00)	840 (95)	7,060 (797)	.035 (.85)	PFA300	3.00 (76.2)	5.50 (139.7)	4.47 (113.5)	1.13 (28.7)	M6	5	90 (10)	2.70 (1.22)
			1,800 (205)	19,530 (2,207)	.035 (.85)								PFS300	110 (12)

Angular: 4 degrees Axial: +/- .020in (.50mm) Max. RPM: 6,000

Lightly grey shaded boxes indicate stainless steel (CRES)

Conversion from Horsepower to Torque:  $(HP \times 63,000) \div RPM = Trq$  (lbin) or  $(HP \times 7,119) \div RPM = Trq$  (Nm)

Note 1 Shaft sizes less than or equal to the Max w/RELIEF can penetrate to the center of the coupling. See drawing.

Note 2 Shaft sizes greater than the Max w/RELIEF up to the Max w/STEP BORE can only penetrate to the B dimension. See drawing.

Note 3 Dynamic torque ratings are momentary values. For non-reversing applications, divide by 2.

Divide by 4 for reversing applications. Should the torque ratings be marginal for your application, contact us for analysis.

The **PF Series (PowerFlex)** power transmission coupling uses the proven HELI-CAL Flexure to provide reliable torque transmission between shafts, while allowing for substantial angular and parallel misalignment compensation. The **PF Series** also incorporates the convenience of interchangeable bushings, providing for quick and easy changes in bore sizes, while using the same HELI-CAL FLEXIBLE COUPLING center section. This means both fast initial delivery (separate bushings and center section are assembled for shipment from inventory), and the ability to change the coupling's bore sizes without remachining when the coupling is already in use (just order new bushings precision bored to your needs).

The relief feature allows the shafts to penetrate into the Flexure area. With step bores, the shafts are inserted into the tapered bushings only, to dimension B.

To make things even simpler, the need for keyways has been eliminated. By designing the tapered bushings to hold more torque than the maximum torque capacity of the coupling, sizing and placement of keyways is no longer an issue. The **PF Series** is available in both aluminum and corrosion resistant steel (CRES).

**Attachment:**  
Tapered bushing

**Materials:**  
PFA: 7075-T6  
Aluminum alloy  
center-section  
and bushings

PFS: 15-5 PH  
H900 CRES  
center section;

303 CRES  
bushings

M6.0 Hex Head Cap Screw 5 places (M5.0 Hex Head Cap Screw 4 places on PFA/PFS 200)

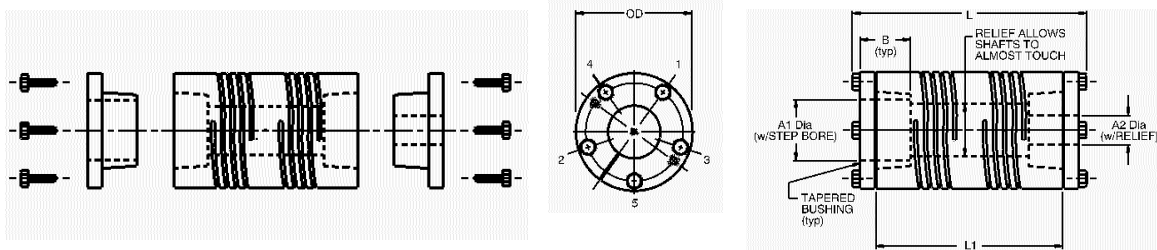

\*Seating of screws: For correct installation, progressively tighten screws to specified torque in sequence shown above.

**HELICAL Adapter Hubs, AH Series**

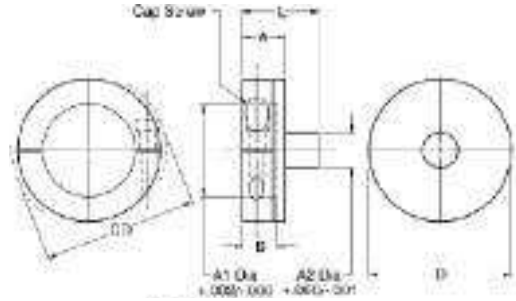

Sample part number: AH250-52-20. Material: Aluminum Alloy.

Basic Model Number	Dimensional Information					Screw Size	Bore Diameter	
	D Diameter (in.)	CD Clearance Diameter (in.)	L Length (in.)	A Dimension (in.)	B Dimension (in.)		Maximum A1 diameter +.002 / -.000 (in.)	Designator (1/32nd in.)
AH150	1 1/2	1.68	.92	.59	.50	10-24	.875	-28
AH200	2.0	2.22	1.00	.67	.58	1/4-20	1.250	-40
AH225	2 1/4	2.46	1.00	.67	.58	1/4-20	1.500	-48
AH250	2 1/2	2.71	1.35	.75	.61	1/4-20	1.750	-56
AH300	3.0	3.31	1.50	.90	.77	5/16-18	2.125	-68
AH350	3 1/2	3.81	1.50	.90	.77	5/16-18	2.625	-84
AH400	4.0	4.28	1.60	1.00	.87	3/8-16	2.875	-92

**HELICAL Bore Reducers, BR Series**

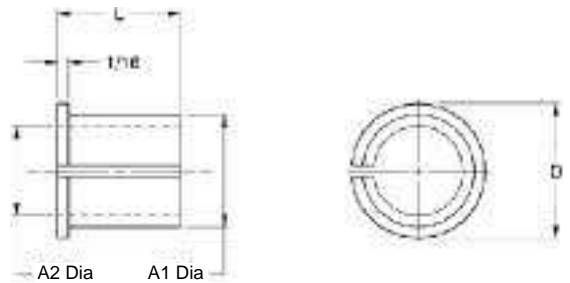
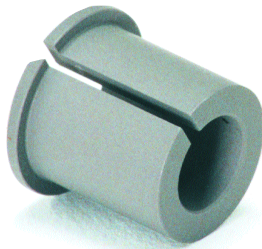

Sample part number: BR075-20-16. Material: Aluminum Alloy.

Basic Model Number	Dimensional Information		Standard Diameters			
	D Diameter (in.)	L Length (in.)	A2 diameter (.000 / -.001) (in.)		A1 diameter (+.002 / -.000) (in.)	
			Designator (1/32nd in.)	Designator (1/32nd in.)	Designator (1/32nd in.)	Designator (1/32nd in.)
BR050	1/2	7/16	.375	-12	.250	-8
					.313	-10
BR062	5/8	9/16	.500	-16	.250	-8
					.313	-10
					.375	-12
BR075	3/4	11/16	.625	-20	.313	-10
					.375	-12
					.500	-16
BR087	7/8	13/16	.750	-24	.375	-12
					.500	-16
					.625	-20

## HELICAL Shaft Collars - Clamp Style, CL Series

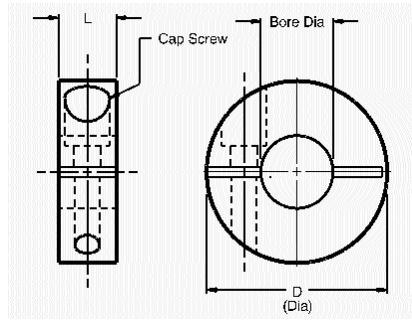

Sample part number: CLS062-8. Material: Aluminum Alloy or Stainless Steel.

Basic Model Number		Dimensional Information		Screw Size	Standard Bore Diameters	
Aluminum Alloy	Stainless Steel	D Diameter (in.)	L Length (in.)		+0.002 / -0.000 (in.)	Designator (1/32nd in.)
CLA050	CLS050	1/2	7/32	2-56	.125 .188*	-4 -6*
CLA062	CLS062	5/8	1/4	4-40	.188* .250*	-6* -8*
CLA075	CLS075	3/4	5/16	6-32	.250* .313*	-8* -10*
CLA100	CLS100	1	3/8	8-32	.313 .375* .500*	-10 -12* -16*
CLA125	CLS125	1 1/4	7/16	10-24 (aluminum) 10-32 (stainless)	.375* .500* .625*	-12* -16* -20*

\* Clearance diameter for this bore

## HELICAL Solid Couplings, SC Series

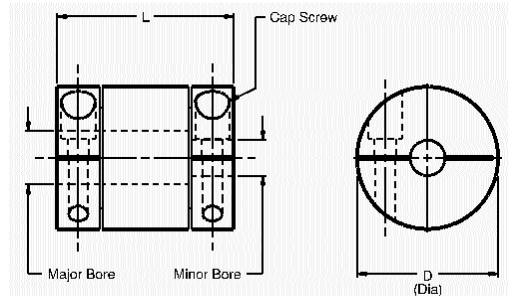
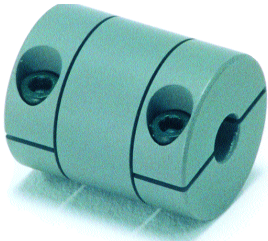

Sample part number: SCA100-12-8. Material: Aluminum Alloy or Stainless Steel

Basic Model Number		Dimensional Information		Screw Size	Standard Bore Diameters	
Aluminum Alloy	Stainless Steel	D Diameter (in.)	L Length (in.)		+0.002 / -0.000 (in.)	Designator (1/32nd in.)
SCA050	SCS050	1/2	3/4	2-56	.094 .125	-3 -4
SCA062	SCS062	5/8	.80	2-56	.125 .157 .188	-4 -5 -6
SCA075	SCS075	3/4	.90	4-40	.125 .188 .250 .375*	-4 -6 -8 -12*
SCA100	SCS100	1	1 1/4	8-32	.250 .313 .375*	-8 -10 -12*
SCA125	SCS125	1 1/4	1 5/8	10-24 (aluminum) 10-32 (stainless)	.375* .500* .625*	-12* -16* -20*

\* Clearance diameter for this bore

## Helical's X-Series, Radial (Cross) Slot, Flexible Couplings

**Torsionally Stiff ... Zero Backlash ... No Maintenance ... User Friendly**

### What

Helical Products Company's new X-Series is a high performance, easy to use, durable, full featured, radial (cross) slot flexible coupling with high torque capacity and exceptional torsional stiffness. It is offered in six different outside diameters and a wide range of bore sizes. It features the reliable, user friendly, Helical integral clamp attachment.

### Why

The X-Series coupling was developed to complement Helical's coupling offerings by bridging the gap between the versatile HELI-CAL Flexure and expensive bellows type couplings. X-Series couplings are ideal for applications requiring high reversing torque loads along with high torsional stiffness. In the ever changing motion control field, ever faster stop/start cycles are the order of the day. Not only does this require higher torque capabilities for the coupling, it also demands greater torsional stiffness throughout the drive system. Since the flexible coupling is usually the most torsionally flexible component of any motion control system, Helical chose to use the radial, cross-slot design to maximize torsional stiffness.

### Design considerations

The integral clamp fasteners are located inline, on either side of the radial-slot flexing element. This provides the easiest assembly for most applications, where just moving the hex wrench across the flexing element is all it takes to tighten both fasteners.

Along with high torsional stiffness and torque capacity, the X-Series couplings, like all HELI-CAL Flexure couplings, are completely machined from a solid piece of material. This one piece integrity insures that there is never a worry about wear, looseness, and backlash as found in multi-piece assemblies.

To make component assembly as easy and compact as possible, the X-Series features the Helical bore relief. This allows shafts to be inserted into the center of the coupling without affecting the misalignment capability of the coupling. By making the center flexible section with a slightly larger ID than either shaft size, the shafts can be inserted into this area without contacting the flexible element ID during operation.

7075-T6 aluminum is the material of choice for the X-Series. It is ideally suited for use in both the HELI-CAL Flexure and the cross-slot flexing elements. Helical has used this premium material for 40 years in the manufacture of flexible couplings. As compared

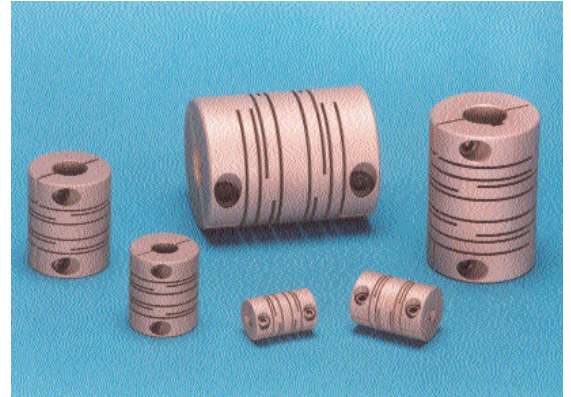

Ideal for motion control applications.  
Low cost alternative to bellows type couplings.  
Available in 7075-T6 aluminum.  
Excellent fatigue resistance.

to other exotic materials, 7075-T6 aluminum provides the ideal balance between cost and engineering properties. It has a high yield point, excellent fatigue resistance, and 1/3rd the rotational inertia of comparable steel couplings, allowing faster motion response for the same torque.

### Test results

Helical X-Series couplings have been subjected to the same rigorous reliability testing as all Helical couplings. During durability tests, couplings are subjected to parallel offsets of up to five times their rated value and tested to failure. The Helical X-Series couplings tested for tens of millions of cycles at these exaggerated offsets and exhibited an exceptional premium performance capability.

### In brief

Helical's X-Series single-piece couplings offer a cost effective balance between couplings that are too stiff radially and those not stiff enough torsionally for servo-type applications. This coupling features high torsional stiffness, low radial loads, one-piece integrity, good flexibility, and zero backlash. The X-Series coupling is an excellent, low cost alternative to bellows type couplings and ideal for AC and DC servomotor type applications. Created for high performance motion control systems, the X-Series incorporates two flexible element sets – combining greater end-to-end rotational accuracy with radial flexibility – in one design. Available in six outside diameter sizes, from 15mm to 50mm and any bore combination between the listed minimum and maximum. Couplings can be ordered with bores that are either millimeter, inch or combination of the two.



## Selection Chart for "very stiff," HELICAL X-Series Flexible Couplings

Bore Diameter (+.05 / - .00 mm)		Performance Data			Basic Model Number	Dimensional Information		Inertia † X 10 <sup>-4</sup> (kgcmsec <sup>2</sup> )	Attachment Metric Cap Screws		Weight (grams)
Min (mm)	Max (mm)	Torque rating (Nm)	Torsional Stiffness (Deg/Nm)	Parallel offset (Deg/Nm)		OD (mm)	L (mm)		Size (mm)	Seating torque (Nm)	
3.00	6.00	0.30	1.13	0.10	<b>XCA15</b>	15*	24	0.028	M2.50 - .45	1.1	9.2
4.00	8.00	0.50	.046	0.10	<b>XCA20</b>	20**	28	0.11	M3 - 5	2.0	20
6.00	10.00	1.00	0.22	0.15	<b>XCA25</b>	25	30	0.30	M3 - 5	2.0	33
9.00	12.70	2.00	0.13	0.15	<b>XCA30</b>	30	38	0.78	M4 - 7	4.7	60
10.00	17.00	5.00	.066	0.20	<b>XCA40</b>	40	60	3.9	M5 - 8	9.5	177
12.00	22.23	10.00	.029	0.20	<b>XCA50</b>	50	65	10.5	M6 - 1.0	16	306

Angular: 3 degrees Axial: +/- .25mm Max. RPM: 10,000  
Keyways available upon request with XCA40 and XCA50

\* Clearance diameter for cap screw = 17.5mm  
\*\* Clearance diameter for cap screw with bores over 6.35mm = 21.8mm  
† Inertia is based on smallest standard bore

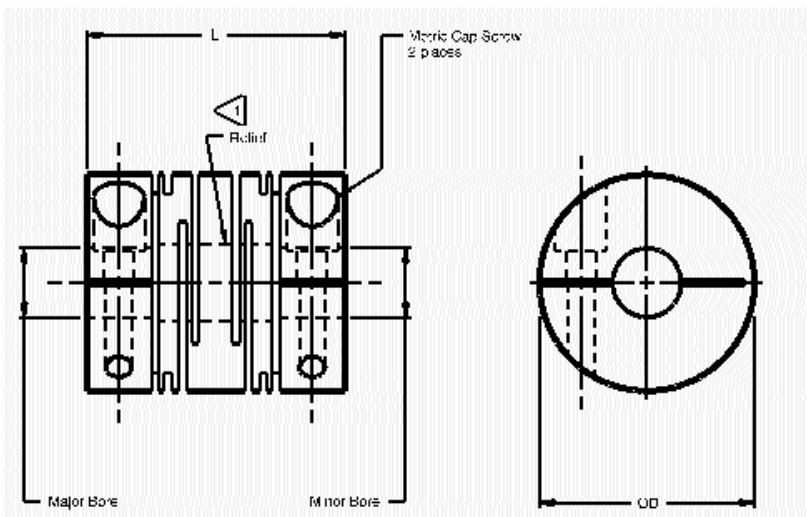

1 Major and minor diameter shafts may enter flexing area during operation.

## How To Order

### Example

#### Basic Model Number

(X = cross-slotted coupling, C = integral clamp, A = aluminum)

#### Outside Diameter Designator

**XCA25 - 10mm - 8**

#### Minor Bore Designator

#### Major Bore Designator

Metric bores are specified as millimeter size (-10mm).  
Inch bores are expressed as number of 32nds (-8 = 8/32 = 1/4" = .250").

### A New Angle on Universal Joints

#### HELI-CAL Flexured U-joints Provide Precision Operating Characteristics

A universal joint is a mechanical connection between rotating shafts which are generally not in parallel, but intersecting. "U-joints" transmit torque.

U-joints are used in a variety of applications, wherever handling significant angular misalignment is the main focus. Typical applications include: articulating mechanisms, food processing equipment, replacement for expensive gearboxes, and drives where motor position must be moved angularly off centerline of the driven unit.

The oldest and most common type of u-joint is called the Cardan or Hooke type joint. It consists of hub yokes, connected by a cross shaped intermediate member. These popular u-joints are frequently used in automotive applications. Because the design incorporates several different piece parts, the moving parts of this type of u-joint usually require lubrication; and as the joint wears, the amount of backlash or free play within the joint itself grows. Even a lubricated Cardan u-joint will require periodic maintenance, and may leak lubricant.

Cardan u-joint

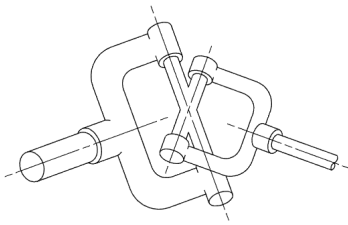

Performance wise, Cardan u-joints can transmit relatively high torque with minimal radial loads. But, by design these u-joints have difficulty compensating for parallel offset and axial misalignment. Cardan types also introduce rotational inconsistencies into drive systems, a phenomenon known as "non-constant velocity rotation."

The HELI-CAL Flexure is an advanced and unique u-joint solution that generally exceeds the capabilities of common u-joint designs. A Helical u-joint is really a flexure capable of over 5° of angular misalignment. It may accommodate up to 90° of angular misalignment in certain circumstances. This type of u-joint will also compensate for axial and parallel misalignment.

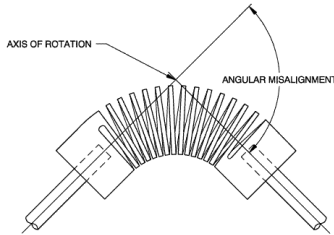

HELI-CAL Flexure

A frequent application of the Helical flexured u-joint is the direct replacement for a 90° bevel gearbox. Gearboxes are expensive, and usually need lubrication for their meshing gear surfaces and bearings. Replacement with a maintenance free Helical flexured u-joint can save money, both on initial purchase price and on maintenance costs. Flexured u-joints can be beneficial most anywhere—for example: aerospace, appliances, electronics, control mechanisms and drives, medical and optical devices, sewing machines, instrumentation, and textile machinery.

The performance capability of each HELI-CAL Flexure is determined by characteristics such as: flexure outside diameter, inside diameter, coil thickness, material, number of coils, and number of starts. By altering these

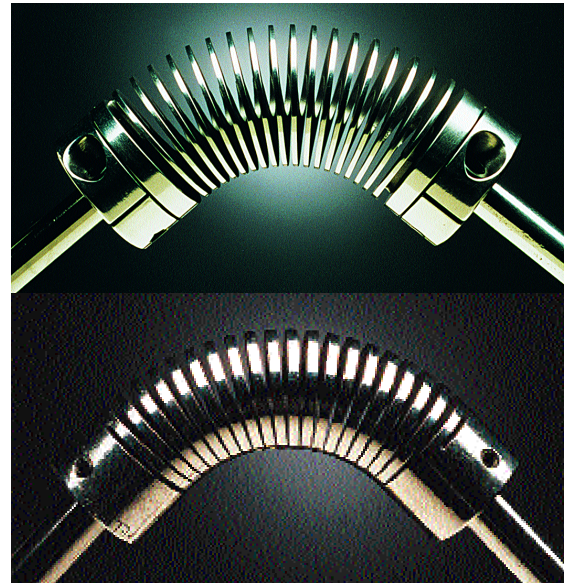

Helical flexured u-joints can be made to suit specific specifications and/or requirements. Note coil widths.

characteristics, torque capacity, angular and parallel misalignment capabilities, torsional and lateral bending rates of flexured u-joints can be made to suit specific specifications and/or requirements.

By using a flexured u-joint, the customer benefits from:

- ◆ Choice of materials
- ◆ Infinite choice of end attachments
- ◆ Optimized misalignment and torque capacities
- ◆ A variety of torsional and lateral bending rates
- ◆ Ability to run in either manual or motor-driven applications
- ◆ Constant velocity

An added bonus—flexured u-joints *do not* have:

- ◆ Backlash
- ◆ Moving parts
- ◆ Maintenance and lubrication requirements
- ◆ Limited selection of capabilities and sizes
- ◆ Limited angular misalignment capability

Once the designer/customer provides Helical with the performance requirements for his/her device, machine, or equipment, a specific flexure design that will meet or exceed application requirements is developed. An attachment may also be specified to securely interface with adjacent components. The result is a Helical flexured u-joint that works as an integral part of the customer's application.

Helical flexured u-joints are tailor-made for customer applications, using customers' specific requirements as a starting point. The finished product is a Helical flexured u-joint that "fits like a glove" in the device, machine, or equipment.

Helical Products Company, with its unique HELI-CAL Flexure, covers most u-joint requirements. Whether the application requires just a small angle of slightly more than 5°, or one calling for a 90° bend, Helical has a "flexure" answer. This "answer" employs the infinitely variable HELI-CAL Flexure, with its amazing range of variable characteristics. No longer is it necessary to use a "one size fits all" approach to u-joints. 

**Flexure Attachments That Make Sense**

**How To Make The Right Connections**

For many years Helical Products Company has been recognized as the pioneer in the design and manufacture of helical beam type couplings, universal joints (UJs) and machined springs. The unique capabilities of the HELI-CAL Flexure have solved countless design projects for engineers in many diverse industries.

But curiously, engineers or designers often fail to recognize how important the integration of the flexure /attachment is in improving component performance. Typically, the portion of a coupling that fastens, clamps, meshes or otherwise contacts adjacent components is referred to as an "attachment." It is these various attachments and their potential impact on system design, we will discuss here.

First, let's consider some of the special characteristics inherent to a HELI-CAL Flexure. Flexured couplings and UJs are backlash free and provide constant velocity rotation regardless of misalignment. Any means of attachment used in conjunction with this type of product should maintain these properties, and complement them. The most common form of coupling attachment, set screws, can introduce backlash into a system unintentionally. Having said this, it should be noted that Helical does sell many flexures with set screw attachments.

[The key to assuring this attachment method does not compromise effectiveness of the entire system is knowing the configuration of the adjacent components, D-shafts for example, and the anticipated duty cycle the component will encounter.]

Clamp style attachments are frequently used as a zero backlash, positive means of transmitting rotational motion between components. When compared to set screws on a performance basis, clamps squeeze around the shaft circumference rather than creating a dimple in the shaft. Clamp attachments better lend themselves to applications where the components are assembled and disassembled occasionally. Clamps require more linear space for the coupling, are inherently less dynamically balanced and slightly more expensive to manufacture. At times neither of



The right attachment will reduce assembly/production costs.

these attachment methods may be optimal for your application. This raises the question,

"What other alternatives do I have?"

The variety of attachments available is limited only by the imagination of the design engineer, and the laws of physics. The configuration of coupling attachments can be as simple as the plain bore or as complex as a pinion gear. The purpose in seeking a customized attachment is to minimize the cost, optimize performance, simplify design, reduce system size, or reduce weight.

By using the HELI-CAL Flexure along with an attachment, the engineers are allowed to dream in their system design. Most designers view a special or modified standard with a cost being too great. In actuality, customized attachments more than pay for themselves. The proper attachment will minimize assembly-production time and reduce the total number of parts to purchase, to maintain in inventory, and to assemble. All of this produces an overall production savings.

Pictured are some examples of customized attachments and the benefits they have provided. 



A threaded shaft attachment offers several advantages. Fine axial length adjustments and blind assembly are just two potential uses.

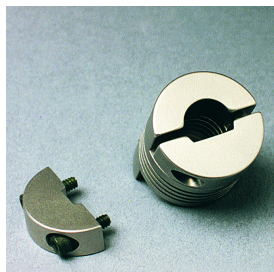

Detachable caps permit flexure installation where components cannot be spread apart to slide the flexure onto component shafts.

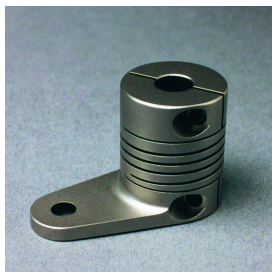

Integrating a lever arm into a clamp attachment flexure allowed linear motion to be converted to rotary motion.



A custom blind attachment flexure designed to transmit torque in a single direction.

**What is a Machined Spring?**

**By Gary L. Boehm**  
**Senior Research Engineer**  
**Helical Products Company, Inc.**

Gary Boehm has spent over 25 years in machined spring R&D. Following are questions frequently asked of Gary regarding machined springs, and his answers.

**Q:** *What is a machined spring?*

**A:** A Helical machined spring is a single piece of material machined into a spring configuration. Key to the versatility of the machined spring is the HELI-CAL Flexure, a flexible helix beam concept utilized in the manufacture of Helical machined springs. Because Helical springs are “machined” to specific design requirements, they provide more precise performance, features and functions than can other more traditional types of springs.

**Q:** *What are some of the advantages of machined springs over conventional springs?*

**A:** With machined springs, desired features or functions can be made part of the spring, such as: special attachments, precise spring rates, multiple integral coils, and other special characteristics. These aspects are generally not possible with traditional springs.

Machined springs also support multiple design objectives such as reliability, repeatability, and integration of multiple parts, which results in a reduction of assembly complexity.

**Q:** *How are machined springs different?*

**A:** The ends of machined springs can be made very square, a beneficial feature for compression springs. Attachments for torsional springs can be integrated so that no forces act upon the spring, just the moment enabling torsional deflections. Extension (tension) springs can include robust attachments that are resistant to breakage. Machined springs can provide very precise, linear deflection rates because virtually all residual stresses are eliminated. As a result, there are no internal stresses to overcome before deflection occurs.

**Q:** *Explain the terms “single start” and “multiple starts.”*

**A:** A Single start spring is a single continuous coil element which starts at one end and terminates at the other end. This configuration is common to most springs.

A “double start” spring has two intertwined continuous coil elements. In effect, this puts two independent helixes in the same cylindrical plane. Multiple start flexures, such as triple start etc., are similar extensions of the concept.

**Q:** *What are some of the benefits of multiple start flexures?*



**A:** Multiple start flexures are beneficial because they not only provide redundant elastic elements should a failure occur, but a failed element (coil) will be physically trapped by the remaining one(s).

Another multi-start benefit applies to compression and tension springs. When compressed (or extended), single start springs provide a reaction force plus a moment. This moment is created because the line of action is through the longitudinal centerline of the spring, and the spring force is action at the coil mean centerline. The distance between these centerlines provides the moment arm of the subject moment. On multiple start flexures, all internal moments are resolved within the spring. The big benefit is that these multiple start springs then compress (or extend) in a very straight manner. There is no tendency for the spring to squirm when deflected, and no restraint is necessary to resolve the free moment.

Sometimes there is a desire to have multiple elastic rates in a given spring. For instance, a compression torsion and lateral bending rate may be specified. With most types of springs accomplishing one of these rates can be a challenge, but three is impossible. Not so with a multiple start Helical machined spring. A machined spring designer can choose coil size, number of coils and multiple start coil features to achieve specified, different, elastic rates.

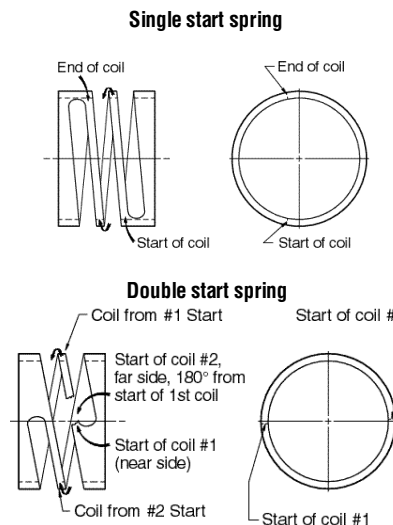

**Q:** *I understand that machined springs can be designed so that the coils don't touch. Does this mean that no sound would be generated by the spring?*

**A:** Exactly. In those applications where resonance is desired for high efficiencies, the best choice is a machined spring of a multiple start configuration. In fact, machined springs may be the only choice under these circumstances. The linear rate and non-contact feature of the machined spring provide outstanding performance. The multiple start aspect prevents lateral bending and lateral translations from compromising in-line motions.

**Proposal Form for Couplings and U-Joints** (Please refer to the literature request form for machined spring proposal forms.)

Name \_\_\_\_\_ Telephone \_\_\_\_\_ E-Mail \_\_\_\_\_

Company \_\_\_\_\_ Fax \_\_\_\_\_

Address \_\_\_\_\_  
Street / P.O. Box City State Zip

**OPERATING INFORMATION**

**1. DRIVE \***

a or b. DIRECTION

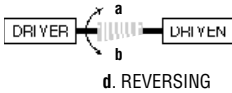

c. CONTINUOUS

d. REVERSING

e. STOP-START \_\_\_\_\_ cycles/sec

f. RPM \_\_\_\_\_ g. MANUAL \_\_\_\_\_

**2. SERVICE \***

a. OPERATING TORQUE \_\_\_\_\_ lbin or Nm.

b. MAXIMUM TORQUE \_\_\_\_\_ lbin or Nm.

**3. MISALIGNMENTS \***

a. ANGULAR \_\_\_\_\_ deg

b. PARALLEL \_\_\_\_\_ in. or mm

c. AXIAL Compression/Extension \_\_\_\_\_ in. or mm

d. SKEW – please provide sketch

**4. TORSIONAL RATE \***

\_\_\_\_\_ deg/lb. in. or deg/Nm

a. less than \_\_\_\_\_ b. equal to \_\_\_\_\_ c. greater than \_\_\_\_\_

**5. INERTIAL LIMITATION / MASS MOMENT OF INERTIA**

\_\_\_\_\_ lb. in. sec<sup>2</sup> or Kg cm sec<sup>2</sup>

a. less than \_\_\_\_\_ b. equal to \_\_\_\_\_ c. greater than \_\_\_\_\_

**6. WEIGHT**

\_\_\_\_\_ oz. or gm.

a. less than \_\_\_\_\_ b. equal to \_\_\_\_\_ c. greater than \_\_\_\_\_

**7. ENVIRONMENT**

a. TEMPERATURE \_\_\_\_\_ °F or °C

b. CORROSIVE \_\_\_\_\_

c. ABRASIVE \_\_\_\_\_

**FLEXURE AND COMPONENT LAYOUT**

8.a.\* PREFERRED OUTSIDE DIAMETER \_\_\_\_\_ in. or mm

MAXIMUM OUTSIDE DIAMETER \_\_\_\_\_ in. or mm

b.\* PREFERRED LENGTH \_\_\_\_\_ in. or mm

MAXIMUM LENGTH \_\_\_\_\_ in. or mm

c.\* DRIVER DESCRIPTION

\_\_\_\_\_  
 \_\_\_\_\_  
 \_\_\_\_\_

d.\* DRIVEN DESCRIPTION

\_\_\_\_\_  
 \_\_\_\_\_  
 \_\_\_\_\_

e.\* SHAFT DIAMETER \_\_\_\_\_

\_\_\_\_\_ in. or mm

g.\* SHAFT TO SHAFT

\_\_\_\_\_ in. or mm

f.\* SHAFT DIAMETER \_\_\_\_\_

\_\_\_\_\_ in. or mm

**9. BORE TOLERANCE**

a. COMMERCIAL

+0.02 in. -.000 in.

or

+0.05 mm -.00 mm

b. PRECISION

+0.0005 in. -.0000 in.

or

+0.015 mm -.000 mm

**ATTACHMENTS**

10. DRIVER*		11. DRIVEN*	
a	INTEGRAL CLAMP	a	
b	2 SET SCREWS AT 120°	b	
c	2 SET SCREWS AT 90°	c	
d	1 SET SCREW	d	
e	ROLL PIN _____ in. or mm	e	
f	DOWEL PIN _____ in. or mm	f	
KEYWAY			
g	_____ type _____	g	
	_____ size _____		
h	OTHER/ DESCRIBE BELOW	h	

**12. MATERIAL**

\_\_\_\_ 7075-T6 ALUMINUM ALLOY

\_\_\_\_ 17-4 PH STAINLESS STEEL

\_\_\_\_ OTHER \_\_\_\_\_

**13. PRODUCTION QUANTITY**

\_\_\_\_ 1-24

\_\_\_\_ 25-100

\_\_\_\_ 100+

\* Items marked with an asterisk are essential for optimum design.

Type of Equipment \_\_\_\_\_

Comments \_\_\_\_\_

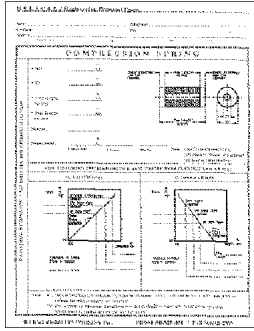

Quantity \_\_\_\_\_  
**ENGINEERING PROPOSAL FORM FOR COMPRESSION SPRINGS**



Quantity \_\_\_\_\_  
**FLEXURE SOLUTION BROCHURE**  
 Discusses the Flexure concept and its uses as a coupling, u-joint, and machined spring.

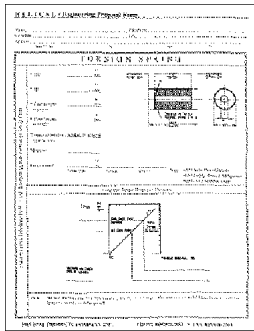

Quantity \_\_\_\_\_  
**ENGINEERING PROPOSAL FORM FOR TORSION SPRINGS**



Quantity \_\_\_\_\_  
**PF SERIES BULLETIN**  
 Presents the many advantages of this innovative power transmission coupling that utilizes the proven HELI-CAL Flexure.



Quantity \_\_\_\_\_  
**X-SERIES BULLETIN**  
 Introduces the new, torsionally stiff X-Series coupling, a low cost alternative to bellows types.

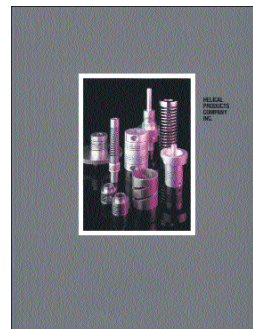

Quantity \_\_\_\_\_  
**CAPABILITIES BROCHURE**  
 Discusses Helical's know how and experience.

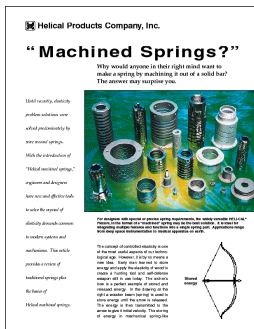

Quantity \_\_\_\_\_  
**MACHINED SPRINGS BROCHURE**  
 Reviews traditional springs, plus the basics of Helical machined springs.



Quantity \_\_\_\_\_  
**NASA TECH BRIEF REPRINT**  
 Presents the case for using machined springs in difficult applications.

If interested in receiving any of the above literature, please fill out the information needed, check the appropriate boxes, note the quantities needed and fax to 805-928-2369. If you have any questions please call 805-928-3851. You may also visit our website at <http://www.Heli-Cal.com>.

Name \_\_\_\_\_ Telephone \_\_\_\_\_ E-Mail \_\_\_\_\_  
 Company \_\_\_\_\_ Fax \_\_\_\_\_  
 Address \_\_\_\_\_  
 Street / P.O. Box \_\_\_\_\_ City \_\_\_\_\_ State \_\_\_\_\_ Zip \_\_\_\_\_



Helical Products Company, Inc. has a unique product in the HELI-CAL Flexure concept. Equally unique and important is the high level of service we at Helical provide to our customers. Together this is our competitive advantage.

When speaking of service we talk of all areas needed to supply the HELI-CAL Flexure to the customer. Putting it in perspective, we like to relate our philosophy to the spokes of a wheel. Each of the spokes represents a unit of our organization - drafting, engineering, finance, administration, shipping, sales, production, manufacturing and marketing. Each in its turn bears the weight of responsibility - and opportunity - to provide and maintain this high level of service to the CUSTOMER - the hub of our wheel.

Passing this commitment on to the next "spoke" requires good, clear communication and cooperation between departments, with the full realization that our focus is always on the customer and their needs. Each department, and, of course, each individual is important at Helical. Helical has never considered itself to be an "I" company, but a "WE" company. With this philosophy we are able to supply an excellent product as well as provide outstanding service at a fair price.

Our commitment has been to build an organization through hard work, fairness, cooperation and mutual trust for each other's roles; to act with courtesy, dependability, reliability, and honesty toward the customer.

Helical does what it says - with pride in its product, its service, and its people. 



The Team



Note: Helical Products Company, Inc., believes the information in this publication is accurate as of its publication date; such information is subject to change without notice.

Helical is not responsible for any inadvertent errors.

The following are trademarks of Helical Products Company, Inc.: HELI-CAL and HELI-CAL Flexure.

# WORLD-WIDE PRODUCT SALES OFFICES



“Man’s mind, once stretched  
by a new idea, never regains its  
original dimensions.”

- Oliver Wendell Holmes



**Helical Products Company, Inc.**

901 W. McCoy Lane, P.O. Box 1069, Santa Maria, CA 93456  
Phone 805-928-3851, fax 805-928-2369 [www.Heli-Cal.com](http://www.Heli-Cal.com)

©Copyright 2001, Helical Products Company, Inc. 010110cat/HJEKTBDD