

Printing and Paper Habasit Belts and Tapes for Printing, Finishing and Paper and Cardboard Converting

Habasit – Solutions in motion

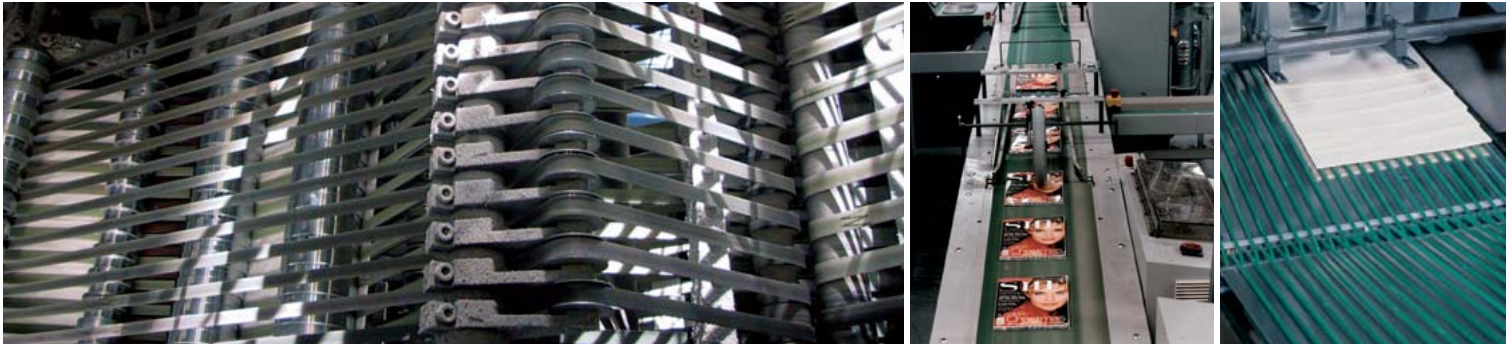

Newspaper / magazine production, folder of web-fed (rotary)



Newspaper/magazine production
Folder of web-fed (rotary) printing machine

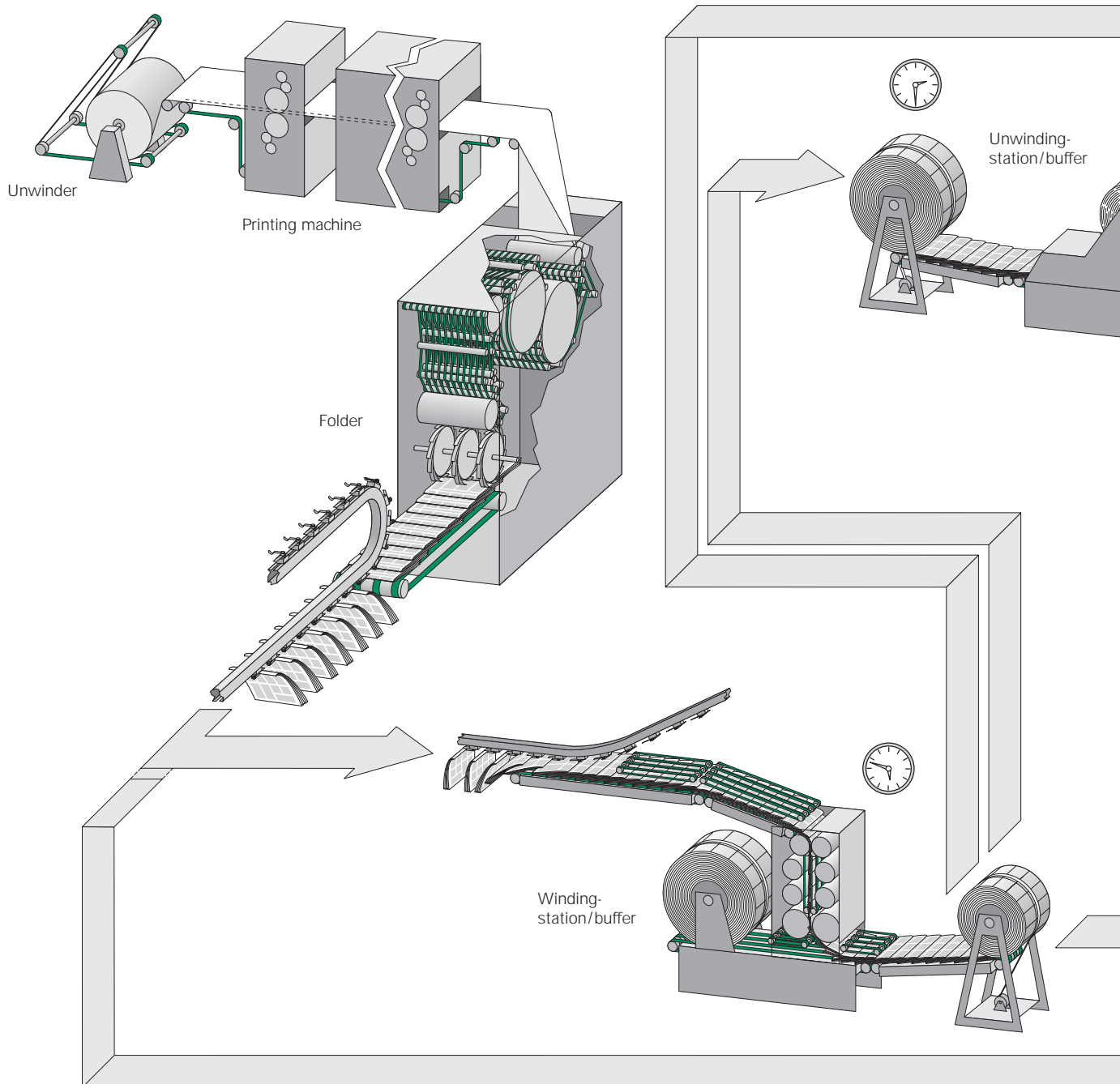

printing machine, printing and mailroom equipment

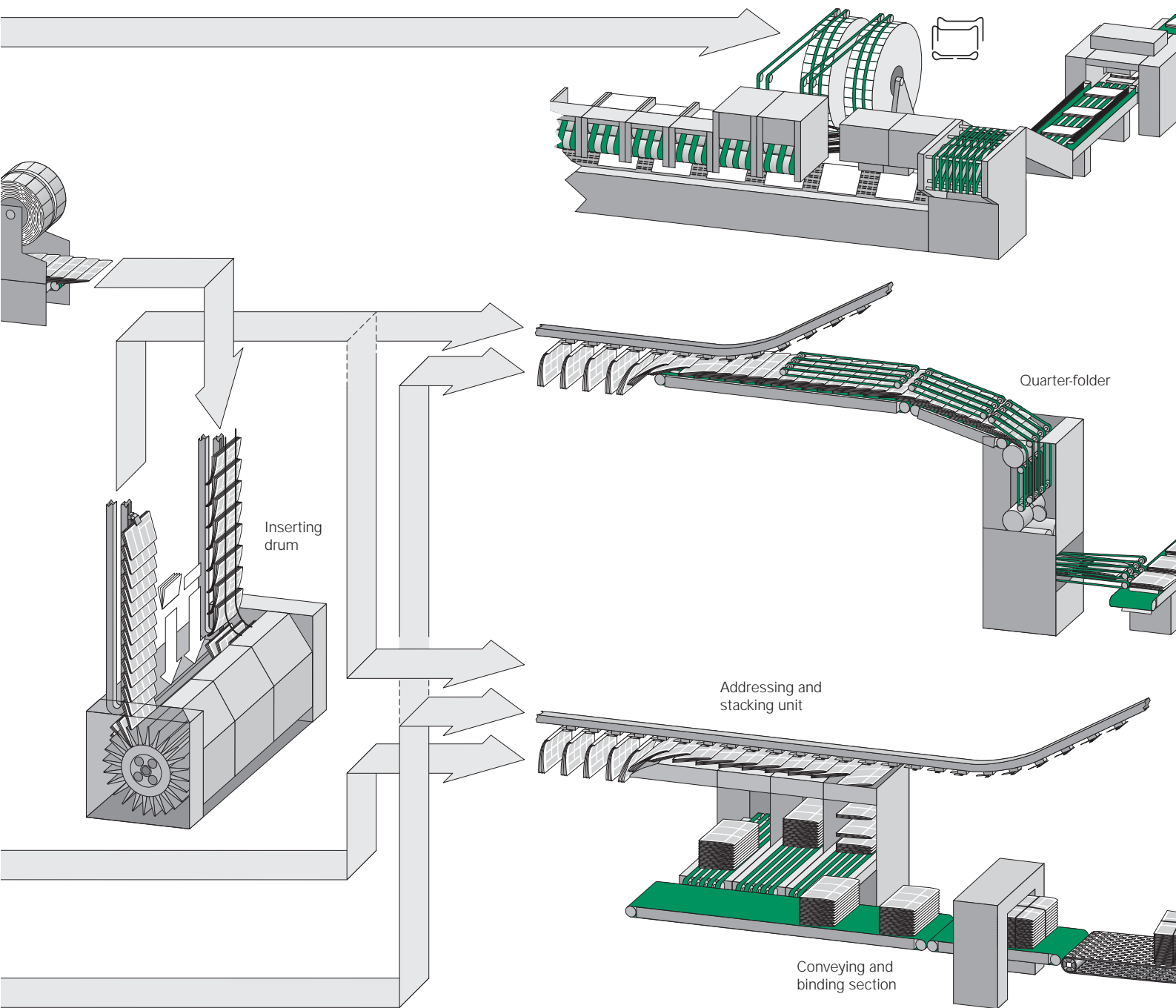

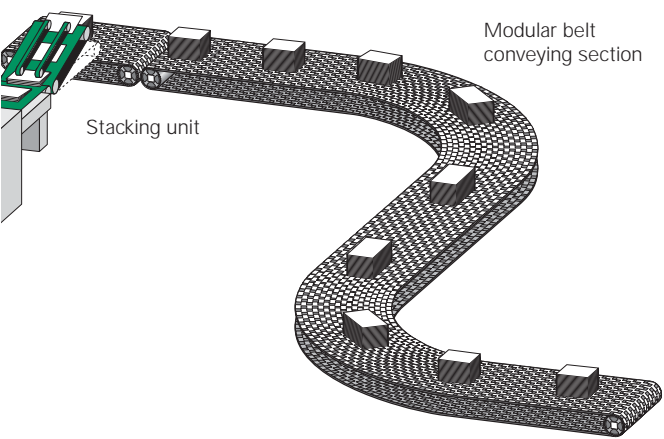

Remark: The drawings show schematic examples of selected applications/processes. The drawings don't lay claim to completeness. The belt recommendations (use/application/layout) can only be considered as a general hint. Due to the complexity of the various processes and technical requirements and the decisive external influences (e.g. nature or property of transported goods, process speed, steps of treatment/handling, environment or process temperature, humidity, chemicals, additives, ingredients, recipes, etc.) there is a large variety of solutions possible.

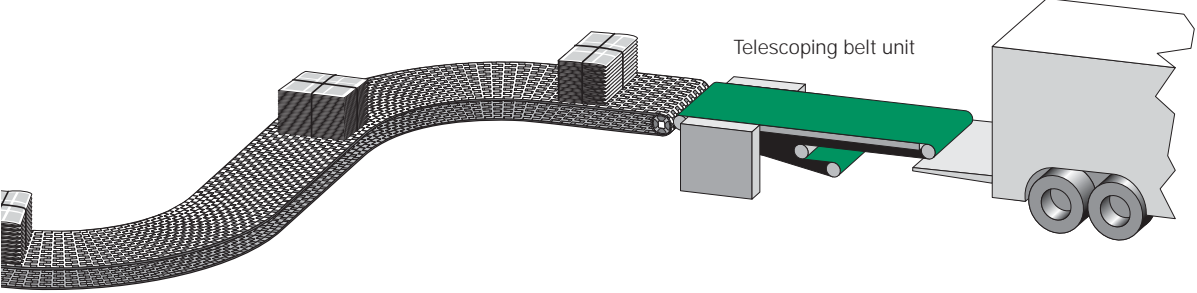
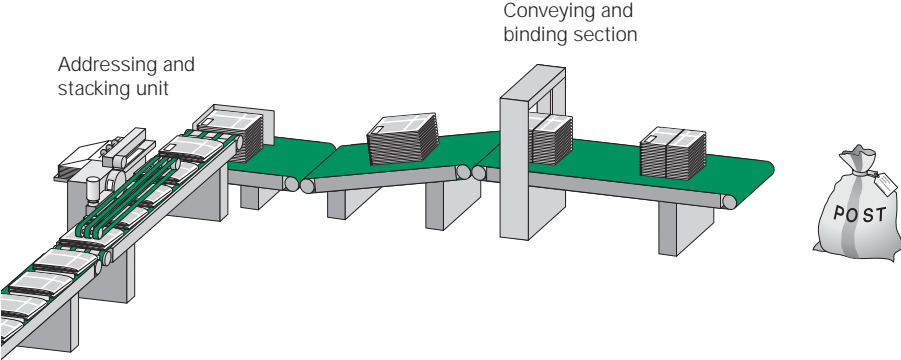

The right choice

Habasit has developed an extensive variety of solutions that allow customers to choose the best product for their specific application.

Habasit is the only belt supplier to manufacture and offer the full package of fabric based and plastic modular belts.

Machine tapes, driving belts, conveyor and processing belts for the printing a

Design/Material/Component variations

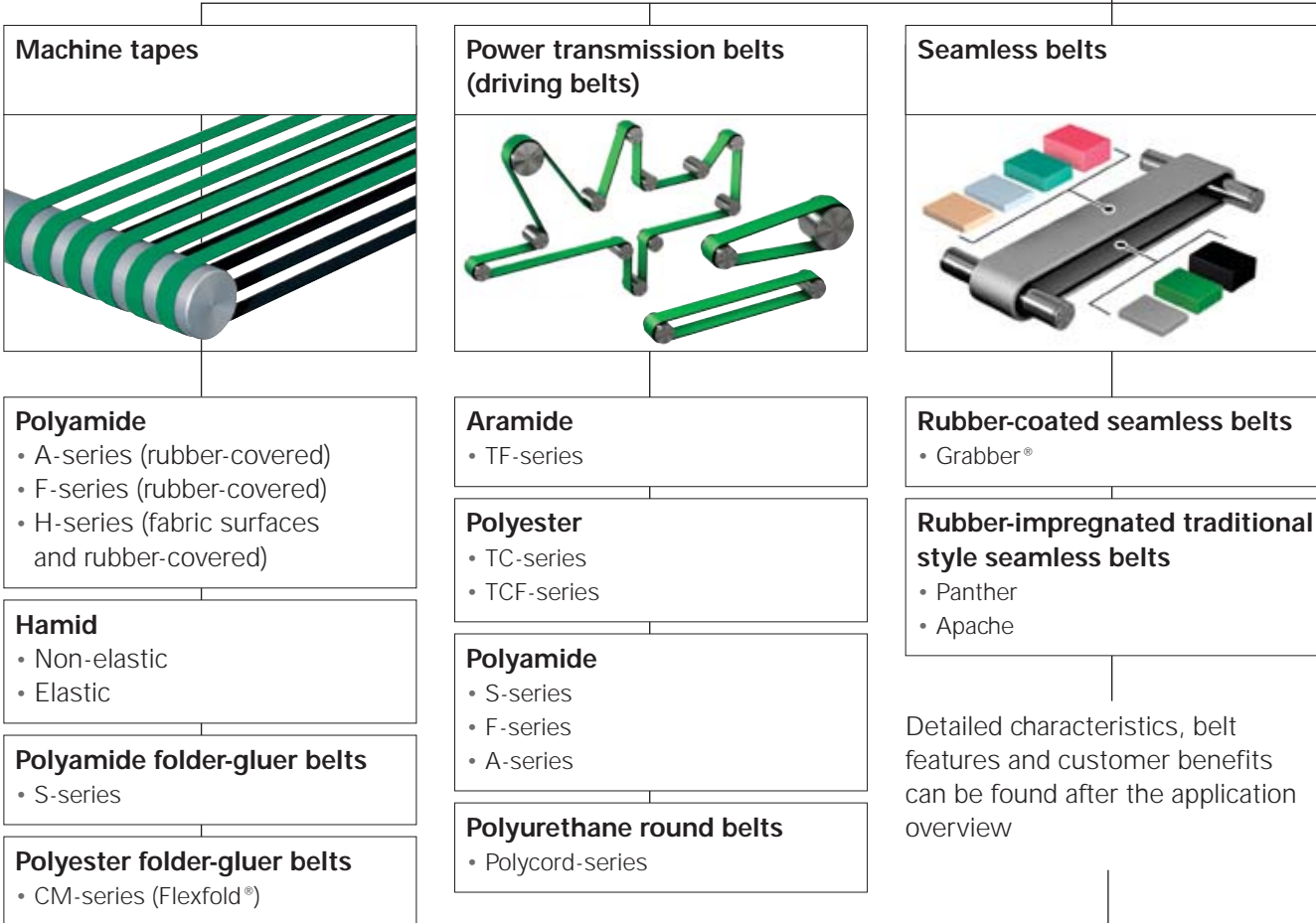

Detailed characteristics, belt features and customer benefits can be found after the application overview

Detailed characteristics, belt features and customer benefits can be found after the application overview

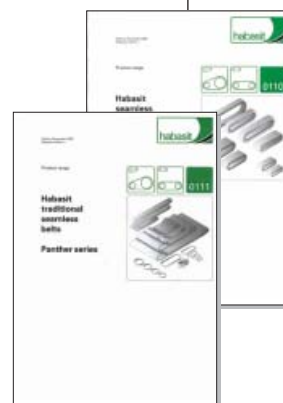

nd paper industry

Fabric conveyor and processing belts

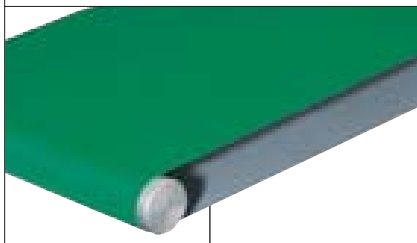

PVC-coated

- N-Line
- Standard Line

High duty conveyor and processing belts

NBR or EPDM covers

Fabric covers

TPU coated

- H... -series
- HAT -series
- HAL -series
- HAR-series
- SAG -series
- F... -series
- E... -series

Nonwoven

- G... -series

Plastic modular belts



PP (Polypropylene)

PE (Polyethylene)

POM/AC
(Polyoxymethylene/Acetal)

PA (Polyamide)

Modular belts are an alternative to fabric based belts predominantly for conveyors, logistics, packaging, warehousing, etc.

Please consult product brochure 4000 HabasitLINK® plastic modular belts for details/further information

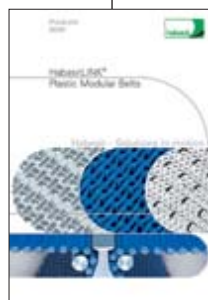

To fulfill a specific process surface structure and material. See following some of the

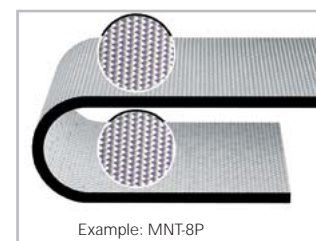
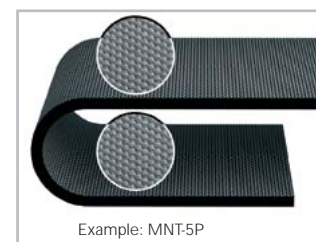
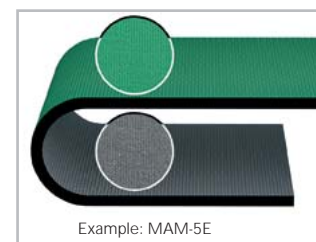
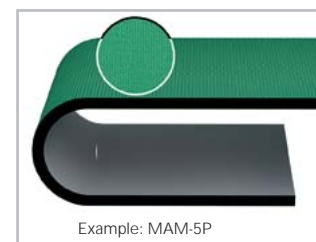

y)

step or a defined function the belt surface plays a key role. Based on material inherent properties a multitude of function possibilities are given. The available varieties of belt surface structures and properties.



Conveying side

- NBR, Mat (dull finish)
- Adhesive

Running side/pulley side

- PUR coated fabric
- Non-adhesive



Conveying side

- PVC, Blank/smooth
- Adhesive

Running side/pulley side

- PET fabric
- Non-adhesive

Example: NAB-8EXDV



Conveying side

- NBR, Fine structure
- Adhesive

Running side/pulley side

- Hamid, Blank/smooth
- Non-adhesive



Conveying side

- NBR, Fine structure
- Adhesive

Running side/pulley side

- NBR, Rough structure
- Adhesive

Example: MAM-04H (elastic)



Conveying side

- NBR, Fine structure
- Adhesive

Running side/pulley side

- NBR, Fine structure
- Adhesive

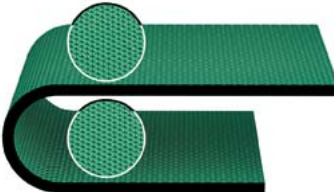

Conveying side

- NBR, Rough textile structure
- Adhesive

Running side/pulley side

- NBR, Rough textile structure
- Adhesive

Example: CM-14/30F



Conveying side

- PUR coated fabric
- Non-adhesive

Running side/pulley side

- PUR coated fabric
- Non-adhesive



Conveying side

- PUR coated fabric
- Non-adhesive

Running side/pulley side

- NBR, Fine structure
- Adhesive

Example: MVT-6P



Conveying side

- PA fabric
- Non-adhesive

Running side/pulley side

- PA fabric
- Non-adhesive



Example:
Cover materials
Various surface materials, hardnesses, coefficients of friction according to function/need

Example: Seamless belt



Conveying side

- NBR, Grip structure
- Adhesive

Running side/pulley side

- PUR impregnated fabric
- Non-adhesive



Substrate components
Various traction layers and substrate materials according to function/need

Printing and paper applications, possible belt types (selection only)

Part A

Belt application	Hamid machine tapes					
	MAT-02H	MAM-04H	MAM-05HP	MAN-05H	MAB-4E	MAB-8E
Sheet feeder/layboy	•	•	•			
Sheet folder	•	•	•			
Folder of web-fed printing machine						
Finishing systems/bookbinding	•	•	•	•	•	•
Newspaper production (printing- and mailroom equipment)	•	•	•		•	•
Sheeter/crosscutter	•	•	•	•		•
Corrugated cardboard production						
Folder-gluer machine						
Tubewinder						
Tissue and diaper production	•	•	•			
Paper and cardboard converting, various kind of applications	•	•	•	•	•	•
Paper conveying	•	•	•	•	•	•
Cardboard conveying						
Feeder belt/pick-off belt						
Driving belt						
Conveyor belt						
Incline belt						
Power turn belt						
Product construction/design						
Conveying side (Material)	NBR	NBR	NBR	PET	TPU	TPU
Conveying side (Surface)	Rough str.	Fine str.	Fine str.	Nonwoven	Fine str.	Fine str.
Conveying side (Property)	Adhesive	Adhesive	Adhesive	Adhesive	Adhesive	Adhesive
Conveying side (Color)	Green	Green	Green	Anthracite	Dark green	Dark green
Traction layer (Material)	Hamid	Hamid	Hamid	Hamid	PET	PET
Number of fabrics	0	0	0	0	1	1
Running side/pulley side (Material)	NBR	NBR	NBR	NBR	TPU	TPU
Running side/pulley side (Surface)	Rough str.	Rough str.	Rough str.	Rough str.	Fine str.	Fine str.
Running side/pulley side (Property)	Adhesive	Adhesive	Adhesive	Adhesive	Adhesive	Adhesive
Running side/pulley side (Color)	Black	Black	Black	Black	Black	Dark green
Friction cover (Material)						
Friction cover (Surface structure)						
Friction cover (Color)						
Traction layer (Material)						
Reverse cover (Material)						
Reverse cover (Surface structure)						
Reverse cover (Color)						
Product characteristics						
Drive determination						
Slider bed suitable	No	No	No	No	No	No
Carrying roller suitable	No	Yes	Yes	Yes	Yes	Yes
Permanently antistatic	Yes	Yes	Yes	Yes	Yes	Yes
Food suitability, FDA conformance						
Technical key data						
Thickness	[mm] 1.4 [in.] 0.06	1.45 0.06	1.6 0.06	1.9 0.07	1.25 0.05	1.25 0.05
Nosebar Radius (minimum)	[mm] [in.]					
Pulley diameter (minimum)	[mm] 15 [in.] 0.6	15 0.6	15 0.6	20 0.8	25 1.0	25 1.0
Pulley diameter minimum with counterflexion	[mm] 15 [in.] 0.6	15 0.6	15 0.6	20 0.8	25 1.0	25 1.0
Tensile force for 1% elongation (k1% after running-in) per unit of width (Habasit standard 320.013)	[N/mm] [lbs./in.]					
Tensile force for 1% elongation (k1% static) per unit of width (Habasit standard 320.064)	[N/mm] [lbs./in.]				4 23	8 46
Tensile force for 1% elongation (k1% static) per unit of width (Habasit standard 320.111)	[N/mm] [lbs./in.]					
Tensile force for 1% elongation (k1% relaxed EN 1723) per unit of width (Habasit standard 320.155)	[N/mm] [lbs./in.]					
Tensile force for 2% elongation (k2% static) per unit of width (Habasit standard QAD-WI-10-35)	[N/mm] [lbs./in.]					
Tensile force for 8% elongation (k8% static) per unit of width (Habasit standard 320.063)	[N/mm] [lbs./in.]	0.9 5	2.4 14	3.5 20	5 29	
Nominal peripheral force per unit of width	[N/mm] [lbs./in.]					
Operating temperature, admissible (continuous)	[° C] - 30/60 [° F] - 22/140	- 30/60 - 22/140	- 30/60 - 22/140	- 30/60 - 22/140	- 20/60 - 4/140	- 20/60 - 4/140
Coefficient of friction on driving pulley of steel	[-] 0.7	0.7	0.7	0.7	0.7	0.7
Seamless manufacturing width	[mm] 1200 [in.] 47	1200 47	1200 47	1200 47	1200 47	1200 47
Joining system						
Thermofix						
Flexproof	•	•	•	•	•	•
Stepflex						
Quickmelt	•	•	•	•		
Mechanical						
	MAT-02H	MAM-04H	MAM-05HP	MAN-05H	MAB-4E	MAB-8E

HSL-8E	HAG-12E	HAL-12E	ENI-10E	
				Belt application
				Sheet feeder/layboy
				Sheet folder
			•	Folder of web-fed printing machine
			•	Finishing systems/bookbinding
				Newspaper production (printing- and mailroom equipment)
	•			Sheeter/crosscutter
	•			Corrugated cardboard production
				Folder-gluer machine
				Tubewinder
				Tissue and diaper production
•	•	•	•	Paper and cardboard converting, various kind of applications
			•	Paper conveying
•	•	•		Cardboard conveying
				Feeder belt/pick-off belt
				Driving belt
•	•	•	•	Conveyor belt
•		•		Incline belt
				Power turn belt
				Product construction/design
TPU	NBR	EPDM	TPU	Conveying side (Material)
Longitudin.	Grip str.	Longitudin.	Impr. fabric	Conveying side (Surface)
Upper-adh.	Adhesive	Super-adh.	Non-adh.	Conveying side (Property)
Dark green	Green	Green	Light grey	Conveying side (Color)
PET	PET	PET	PET	Traction layer (Material)
2	2	2	2	Number of fabrics
PET/TPU	PUR	PUR	TPU	Running side/pulley side (Material)
Impr. fabric	Impr. fabric	Impr. fabric	Impr. fabric	Running side/pulley side (Surface)
				Running side/pulley side (Property)
Grey	Black	Black	Light grey	Running side/pulley side (Color)
				Friction cover (Material)
				Friction cover (Surface structure)
				Friction cover (Color)
				Traction layer (Material)
				Reverse cover (Material)
				Reverse cover (Surface structure)
				Reverse cover (Color)
				Product characteristics
				Drive determination
Yes	Yes	Yes	Yes	Slider bed suitable
Yes	Yes	Yes	Yes	Carrying roller suitable
Yes	Yes	Yes	Yes	Permanently antistatic
No	No	No	No	Food suitability, FDA conformance
				Technical key data
1.9	5.8	2.5	1.5	[mm] Thickness
0.07	0.23	0.1	0.06	[in.]
				[mm] Nosebar Radius (minimum)
				[in.]
20	80	48	40	[mm] Pulley diameter (minimum)
0.8	3.1	1.9	1.6	[in.]
40	100	60	48	[mm] Pulley diameter minimum with counterflexion
1.6	3.9	2.4	1.9	[in.]
				[N/mm] Tensile force for 1% elongation (k1% after running-in)
				[lbs./in.] per unit of width (Habasit standard 320.013)
8	20	20	12	[N/mm] Tensile force for 1% elongation (k1% static) per unit
46	114	114	69	[lbs./in.] of width (Habasit standard 320.064)
				[N/mm] Tensile force for 1% elongation (k1% static) per unit
				[lbs./in.] of width (Habasit standard 320.111)
5	12	13	8	[N/mm] Tensile force for 1% elongation (k1% relaxed EN 1723)
29	69	74	46	[lbs./in.] per unit of width (Habasit standard 320.155)
				[N/mm] Tensile force for 2% elongation (k2% static) per unit
				[lbs./in.] of width (Habasit standard QAD-WI-10-35)
				[N/mm] Tensile force for 8% elongation (k8% static) per unit
				[lbs./in.] of width (Habasit standard 320.063)
				[N/mm] Nominal peripheral force per unit of width
				[lbs./in.]
- 30/80	0/100	- 30/100	- 10/60	[°C] Operating temperature, admissible (continuous)
- 22/176	32/212	- 22/212	14/140	[°F]
0.15	0.15	0.15	0.15	[-] Coefficient of friction on driving pulley of steel
2400	1200	1200	4000	[mm] Seamless manufacturing width
94	47	47	157	[in.]
				Joining system
•	•	•	•	Thermofix
•		•	•	Flexproof
				Stepflex
	•	•		Quickmelt
				Mechanical
HSL-8E	HAG-12E	HAL-12E	ENI-10E	

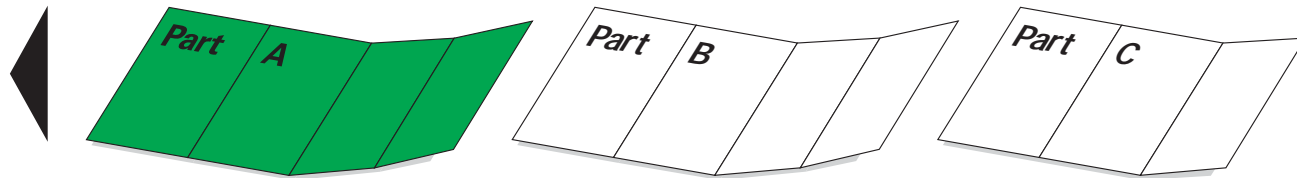

- **Hamid machine tapes**
- **Polyamide machine tapes**
- **NBR or EPDM covers, fabric covers, TPU coated high duty conveyor and processing belts**
- **Polyamide folder-gluer belts**
- **Polyester folder-gluer belts**
- **TPU coated conveyor and processing belts**
- **Nonwoven belts**
- **PVC coated belts**
- **Polyamide power transmission belts (driving belts)**
- **Polyester power transmission belts (driving belts)**
- **Aramide power transmission belts**
- **Polyurethane round belts**

Remarks

All data are approximate values under standard climatic conditions: 23 °C/73 °F, 50% relative humidity (DIN 50005/ISO 554), and are based on the Habasit Master Joining Method.

Legend

Blank/smth.	= Blank/smooth
DSPT	= Double-sided power transmission
EPDM	= Ethylenpropyleneterpolymer (also called EPT)
Grip str.	= Grip structure
gro.	= Groove
grp.	= Grip
Hamid	= Habasit thermoplastic compound
Hard non-adh.	= Hard non-adhesive
Impr. fabric	= Impregnated fabric
Longitudin.	= Longitudinal groove structure
Mat	= Mat (dull finish)
Max	= Maximum
Medium-adh.	= Medium-adhesive
Min	= Minimum
NBR	= Acrylonitrile-Butadiene-Rubber
Non-adh.	= Non-adhesive
Nonwoven	= Web/fleece
PA	= Polyamide
PE	= Polyethylene
PET	= Polyester
PET/NBR	= Polyester fleece saturated with Acrylonitrile-Butadien-Rubber
PET/PUR	= Polyester fabric impregnated with Polyurethane

PET/PVC	= Polyester fleece saturated with Polyvinylchloride or polyester fabric impregnated with Polyvinylchloride
POM	= Polyoxymethylene
PP	= Polypropylene
PUR	= Polyurethane cross linked
PVC	= Polyvinylchloride
Quadrillé	= Quadrangular pattern
Sawtooth	= Sawtooth profile structure
str.	= Structure
Super-adh.	= Soft, super-adhesive
TPO	= Polyolefine thermoplastic
TPU	= Polyurethane thermoplastic
Transp.	= Transparent (clear)
Waffle struct.	= Waffle structure

- applicable
- ◐ conditionally applicable
- not applicable

Product key data overview

You will find the key data for most Habasit products on the Habasit website:

www.habasit.com

How to find (example)

www.habasit.com

- Worldwide
- Select continent (Europe)
- Select country (Great Britain)
- Products
- Conveyor belts
- Select product group
- Overview

Detailed technical data for each product/belt type

With one more click on the respective belt type, you will obtain a technical data overview, showing details such as:

- Product designation/features
- Product design/built-up
- Product characteristics
- Technical data etc.

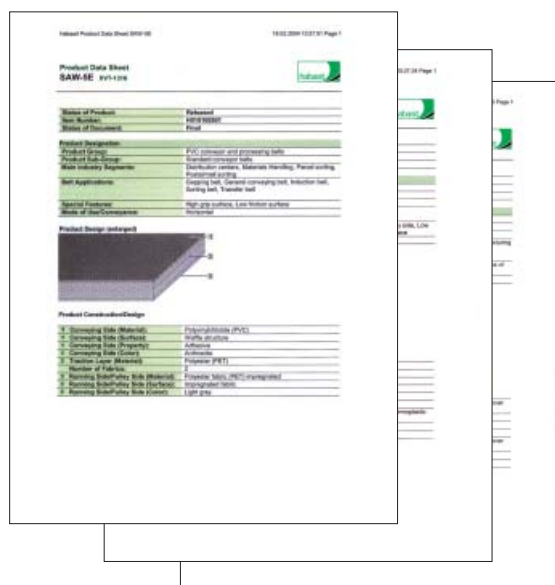

Printing and paper applications, possible belt types (selection only)

Part B

Belt application	Polyamide folder-gluer belts			Polyester folder-gluer belts		
	S-10/30	S-10/40	S-18/60	CM-14/30F	CM-14/40F	CM-14/50F
Sheet feeder/layboy						
Sheet folder						
Folder of web-fed printing machine						
Finishing systems/bookbinding						
Newspaper production (printing- and mailroom equipment)						
Sheeter/crosscutter						
Corrugated cardboard production	•	•	•	•	•	•
Folder-gluer machine	•	•	•	•	•	•
Tubewinder	•	•	•	•	•	•
Tissue and diaper production						
Paper and cardboard converting, various kind of applications	•	•	•	•	•	•
Paper conveying						
Cardboard conveying	•	•	•	•	•	•
Feeder belt/pick-off belt						
Driving belt				•		
Conveyor belt						
Incline belt						
Power turn belt						
Product construction/design						
Conveying side (Material)	NBR	NBR	NBR	NBR	NBR	NBR
Conveying side (Surface)	Rough str.	Rough str.	Rough str.	Rough str.	Rough str.	Rough str.
Conveying side (Property)	Adhesive	Adhesive	Adhesive	Adhesive	Adhesive	Adhesive
Conveying side (Color)	Dark green	Dark green	Dark green	Dark green	Dark green	Dark green
Traction layer (Material)	PA	PA	PA	PET	PET	PET
Number of fabrics	2	2	2	1	1	1
Running side/pulley side (Material)	NBR	NBR	NBR	NBR	NBR	NBR
Running side/pulley side (Surface)	Rough str.	Rough str.	Rough str.	Rough str.	Rough str.	Rough str.
Running side/pulley side (Property)	Adhesive	Adhesive	Adhesive	Adhesive	Adhesive	Adhesive
Running side/pulley side (Color)	Dark green	Dark green	Dark green	Dark green	Dark green	Dark green
Friction cover (Material)						
Friction cover (Surface structure)						
Friction cover (Color)						
Traction layer (Material)						
Reverse cover (Material)						
Reverse cover (Surface structure)						
Reverse cover (Color)						
Product characteristics						
Drive determination						
Slider bed suitable	No	No	No	No	No	No
Carrying roller suitable	Yes	Yes	Yes	Yes	Yes	Yes
Permanently antistatic	Yes	Yes	Yes	Yes	Yes	Yes
Food suitability, FDA conformance						
Technical key data						
Thickness	[mm] 3	4	6	3	4	5
	[in.] 0.12	0.16	0.24	0.12	0.16	0.2
Nosebar Radius (minimum)	[mm]					
	[in.]					
Pulley diameter (minimum)	[mm] 30	40	60	30	40	50
	[in.] 1.2	1.6	2.4	1.2	1.6	2.0
Pulley diameter minimum with counterflexion	[mm] 30	40	60	30	40	50
	[in.] 1.2	1.6	2.4	1.2	1.6	2.0
Tensile force for 1% elongation (k1% after running-in)	[N/mm] 5.5	5.5	8.5	9.5	9.5	9.5
per unit of width (Habasit standard 320.013)	[lbs./in.] 31	31	49	54	54	54
Tensile force for 1% elongation (k1% static) per unit	[N/mm]					
of width (Habasit standard 320.064)	[lbs./in.]					
Tensile force for 1% elongation (k1% static) per unit	[N/mm]					
of width (Habasit standard 320.111)	[lbs./in.]					
Tensile force for 1% elongation (k1% relaxed EN 1723)	[N/mm]					
per unit of width (Habasit standard 320.155)	[lbs./in.]					
Tensile force for 2% elongation (k2% static) per unit	[N/mm]					
of width (Habasit standard QAD-WI-10-35)	[lbs./in.]					
Tensile force for 8% elongation (k8% static) per unit	[N/mm]					
of width (Habasit standard 320.063)	[lbs./in.]					
Nominal peripheral force per unit of width	[N/mm]					
	[lbs./in.]					
Operating temperature, admissible (continuous)	[° C] 0/100	0/100	0/100	- 20/65	- 20/65	- 20/65
	[° F] 32/212	32/212	32/212	- 4/149	- 4/149	- 4/149
Coefficient of friction on driving pulley of steel	[-] 0.7	0.7	0.7	0.7	0.7	0.7
Seamless manufacturing width	[mm] 1200	1200	1200	1200	1200	1200
	[in.] 47	47	47	47	47	47
Joining system						
Thermofix	•	•	•			
Flexproof				•	•	•
Stepflex						
Quickmelt						
Mechanical						
	S-10/30	S-10/40	S-18/60	CM-14/30F	CM-14/40F	CM-14/50F

