



FLOWFLEX BELT

New

New Flowflex series

Our new Flowflex product line consists of:

- 2120 M side flexing belt
 - 0.5 inch (12.7 mm) pitch
 - 83.8 mm width
 - Sprockets
 - Magnetic curves, steel pins are attracted
 - Nose bars
- Made for conveying PET bottles, glass bottles and cans
 - Offering a small in-line transfer
 - Feeding into packers, product in lanes
 - Compact layout, saving drives
 - Improved product handling

CONVENTIONAL LAYOUT

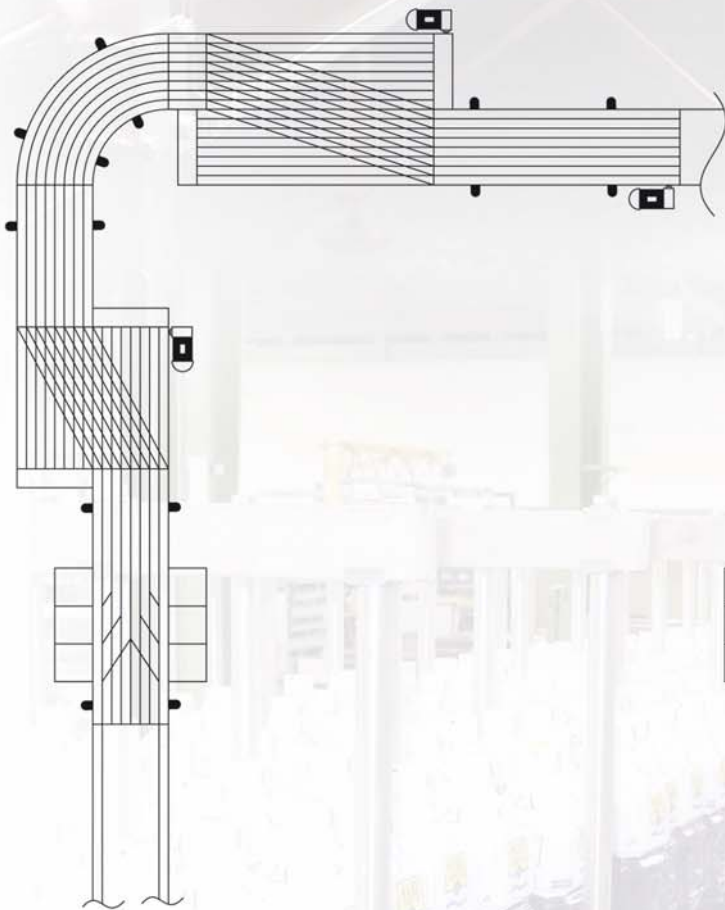

LAYOUT WITH FLOWFLEX

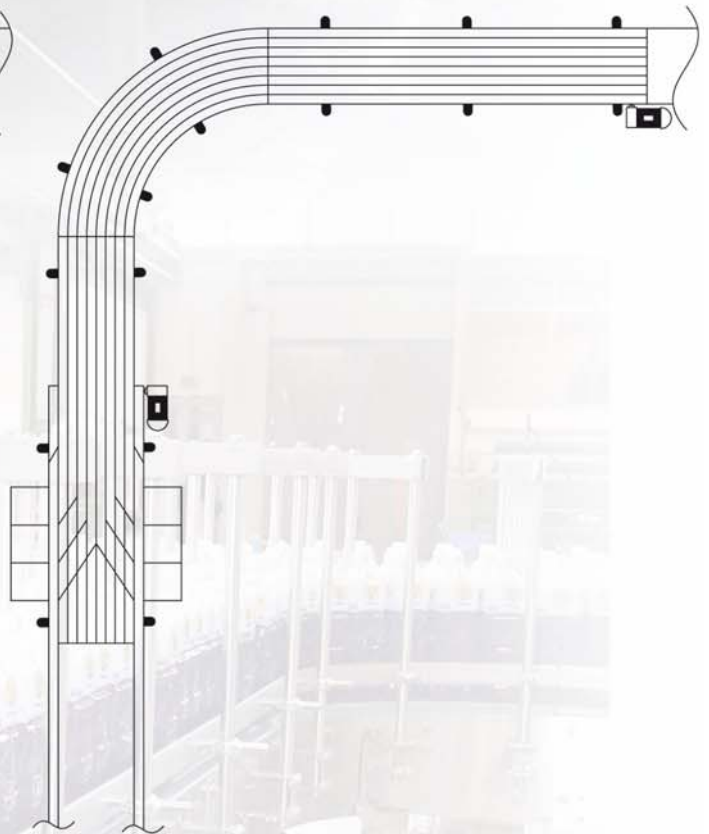

Flowflex features:

- Less belt required
- Less drives required
- Product moves in straight line (no side transfer)
- Less product (label) damage
- Ideal for square bottles as well
- Space saving
- Sideflex radius 500 mm
- Combination with 2120 straight running belts
- One sprocket can do it all
 - 2120 FT, 2120 FG (also NEW!) and 2120 M

CAN BE USED WITH A NOSE BAR
TO CREATE EXTREMELY SHORT TRANSFERS.



New Flowflex series



SIDE TRANSFER



LINEAR TRANSFER WITH FLOWFLEX



SIDE TRANSFER



LINEAR TRANSFER WITH FLOWFLEX

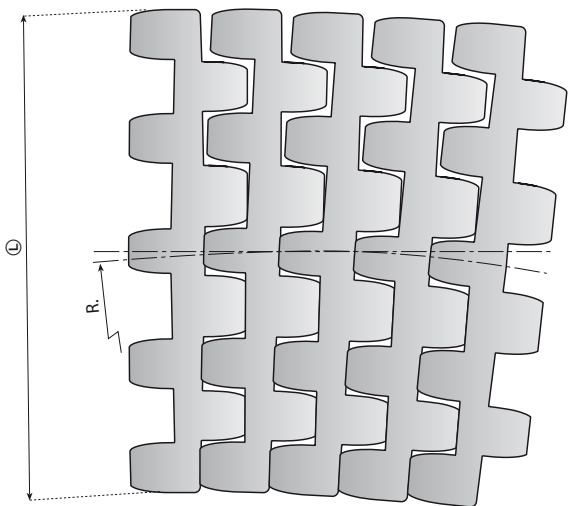
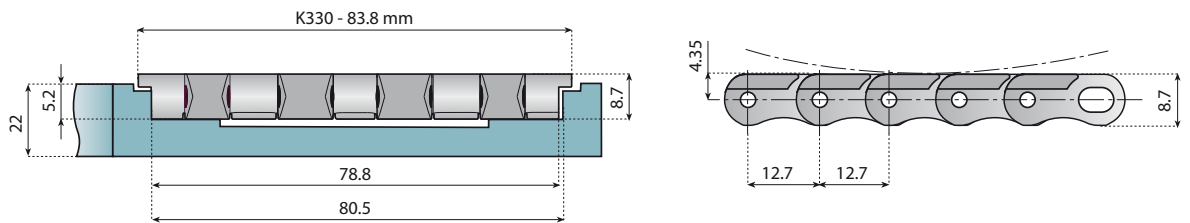
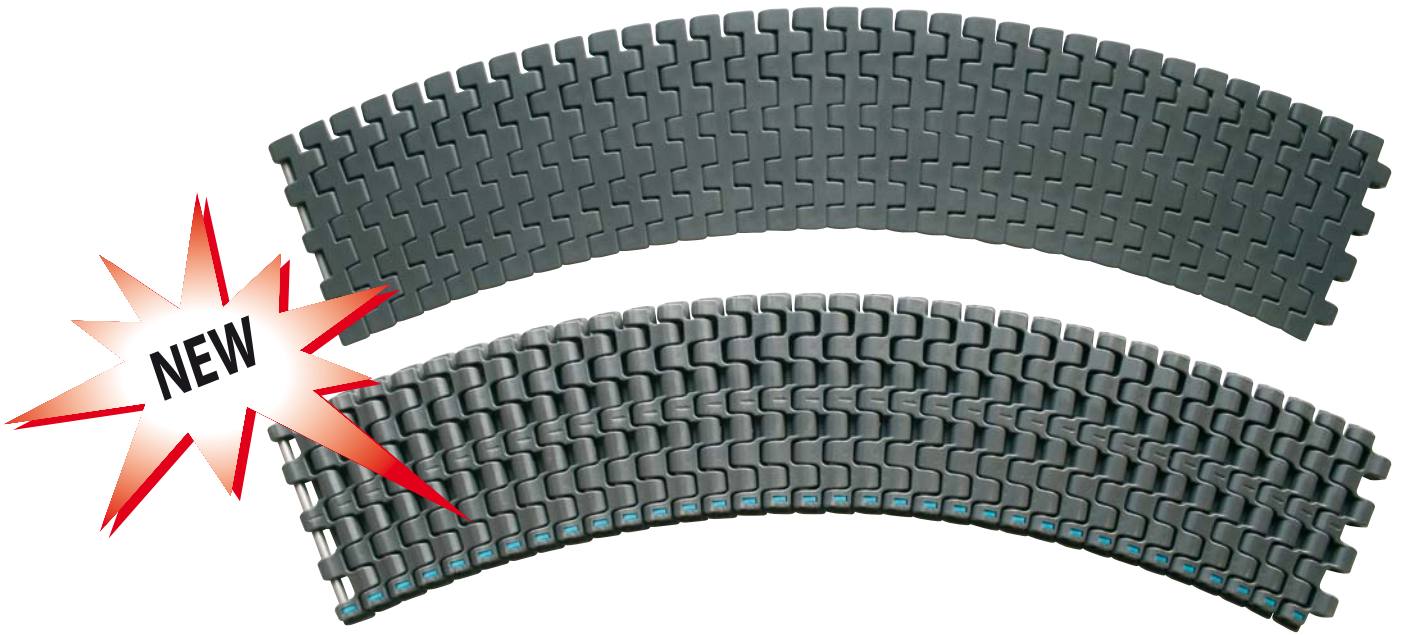

Sideflexing belt for magnetic system

Features:

This system offers a new and unique solution for sideflexing applications in plants with modular conveyors.

Applications:

- To be used in the dry end of the line where bottles or cans run in lanes separated by guides.
- The short pitch makes in-line transfers possible.

Standard length:

240 pitches (10 ft - 3.048 m)

Pin material:

Ferritic Stainless Steel

On request and for adequate quantities these chains can be produced in:

NGG	LFG	XPG	AS	PP
New Generation	Low Friction Acetal Resin (standard material color Dark Grey)	Extra Performance (special material color Dark Brown/Grey)	Anti-static Acetal Resin	Polypropylene



For further engineering information on application of the specified belts, please contact our Technical support.

BELTS - REF.	CODE	Material	Width W		R min.	Max load capacity N	Weight Kg/m
			mm	inches			
LFG 2120 M K330	11340	LFG Dark Grey	83.8	3.30	500	2500	1.11
XPG 2120 M K330	11340XPG	XPG Dark Brown/Grey				2400	
NGG 2120 M K330	11340NGG	NGG Light Grey				2100	

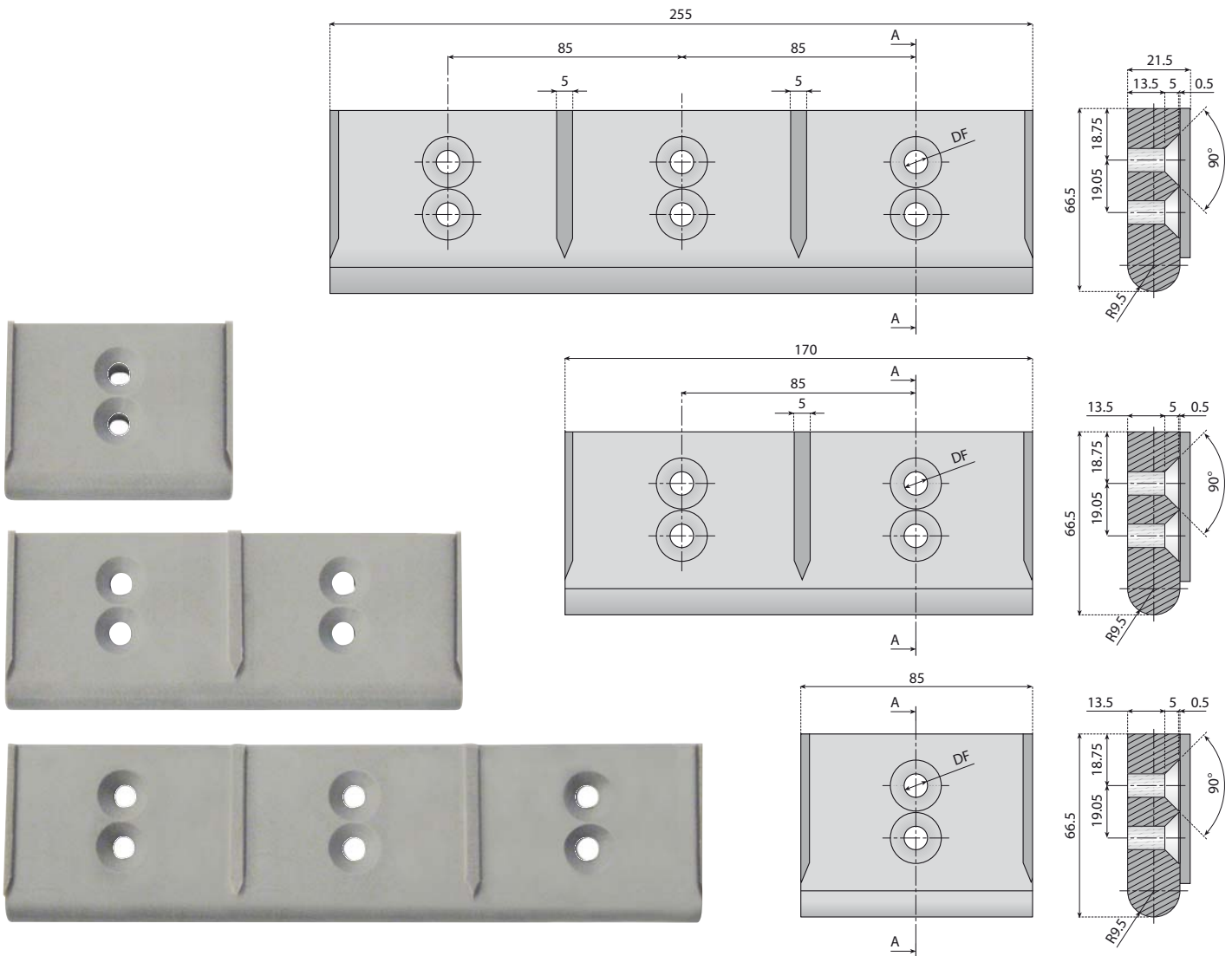

For belts with positioners, grooves can be machined into the nose bar

CAN BE USED WITH A NOSE BAR TO CREATE EXTREMELY SHORT TRANSFERS.

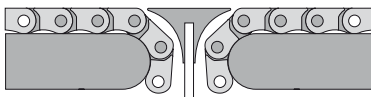

NOW AVAILABLE IN

"NOLU-S"

MATERIAL !

CODE	Total Width mm	Total Height mm	Radius mm	DF mm
14143M	85	19	9.5	8.5
14144M	170			
14145M	255			



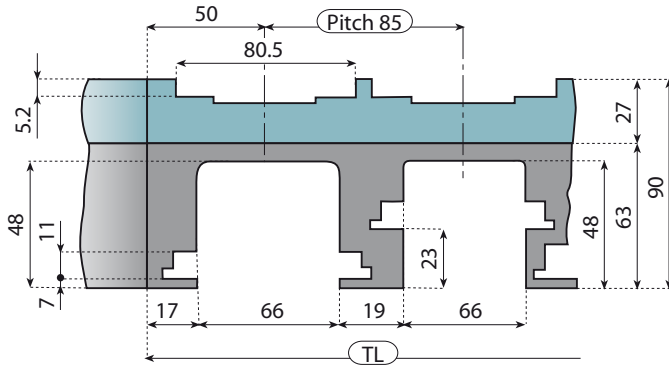

MULTI TRACKS

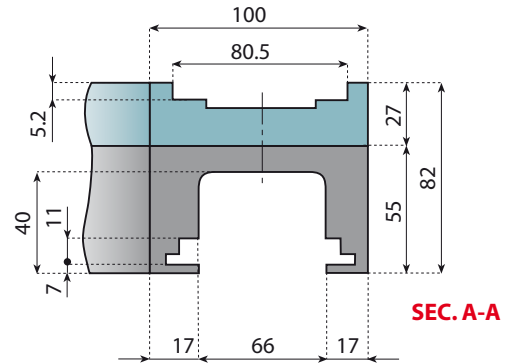

ONE TRACK

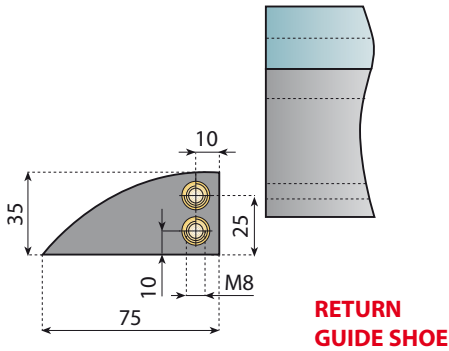

RETURN GUIDE SHOE

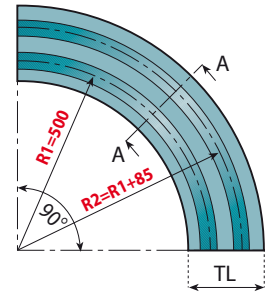

RADIUS

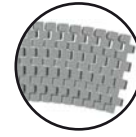

For Sideflexing Belts, type:
2120M

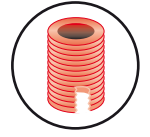

Inserts:
The magnetic corner tracks can be supplied with M8 or M10 brass inserts to your detailed drawing

Now available in
"NOLU-S"
MATERIAL!



Magnetic corner tracks Special Materials
On request magnetic corner tracks for high speed and extremely abrasive applications can be supplied.



Magnetic corner tracks Special Dimensions
On request magnetic corner tracks with special dimensions can be produced.



For further information contact our
Technical support department.

• More tracks and different angles available on request.

Tracks	Total Width TL mm	15°	30°	45°	60°	75°	90°
1	100	KMD.24.15.01.A	KMD.24.30.01.A	KMD.24.45.01.A	KMD.24.60.01.A	KMD.24.75.01.A	KMD.24.90.01.A
2	185	KMD.24.15.02.A	KMD.24.30.02.A	KMD.24.45.02.A	KMD.24.60.02.A	KMD.24.75.02.A	KMD.24.90.02.A
3	270	KMD.24.15.03.A	KMD.24.30.03.A	KMD.24.45.03.A	KMD.24.60.03.A	KMD.24.75.03.A	KMD.24.90.03.A
4	355	KMD.24.15.04.A	KMD.24.30.04.A	KMD.24.45.04.A	KMD.24.60.04.A	KMD.24.75.04.A	KMD.24.90.04.A
5	440	KMD.24.15.05.A	KMD.24.30.05.A	KMD.24.45.05.A	KMD.24.60.05.A	KMD.24.75.05.A	KMD.24.90.05.A
6	525	KMD.24.15.06.A	KMD.24.30.06.A	KMD.24.45.06.A	KMD.24.60.06.A	KMD.24.75.06.A	KMD.24.90.06.A
7	610	KMD.24.15.07.A	KMD.24.30.07.A	KMD.24.45.07.A	KMD.24.60.07.A	KMD.24.75.07.A	KMD.24.90.07.A
8	695	KMD.24.15.08.A	KMD.24.30.08.A	KMD.24.45.08.A	KMD.24.60.08.A	KMD.24.75.08.A	KMD.24.90.08.A

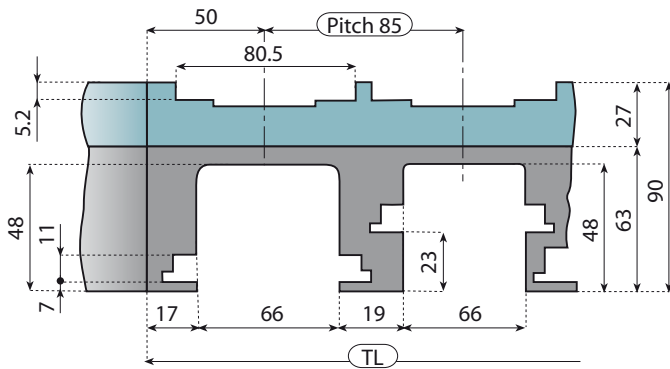

MULTI TRACKS

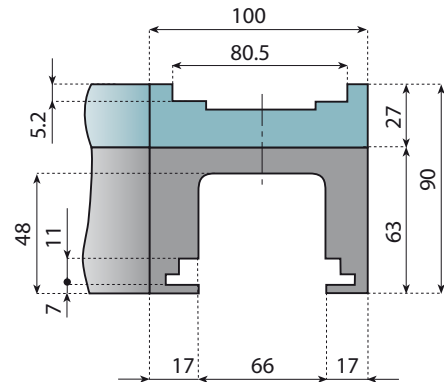

ONE TRACK

SEC. A-A

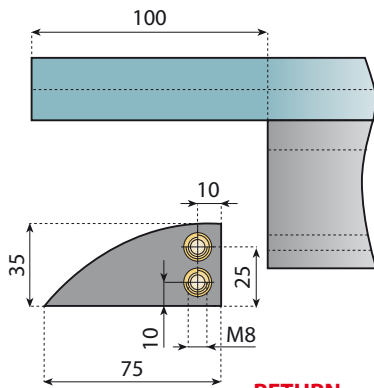

RETURN GUIDE SHOE

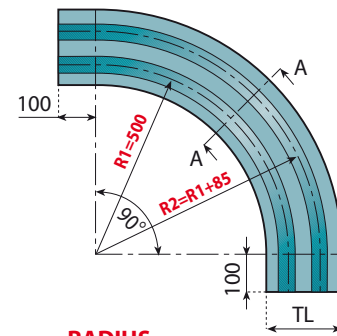

RADIUS

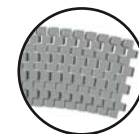

For Sideflexing Belts, type:
2120M

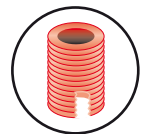

Inserts:
The magnetic corner tracks can be supplied with M8 or M10 brass inserts to your detailed drawing

NOW AVAILABLE IN
"NOLU-S"
MATERIAL !



Magnetic corner tracks Special Materials
On request magnetic corner tracks for high speed and extremely abrasive applications can be supplied.



Magnetic corner tracks Special Dimensions
On request magnetic corner tracks with special dimensions can be produced.



For further information contact our
Technical support department.

• More tracks and different angles available on request.

Tracks	Total Width TL mm	15°	30°	45°	60°	75°	90°
1	100	KMD.25.15.01.B	KMD.25.30.01.B	KMD.25.45.01.B	KMD.25.60.01.B	KMD.25.75.01.B	KMD.25.90.01.B
2	185	KMD.25.15.02.B	KMD.25.30.02.B	KMD.25.45.02.B	KMD.25.60.02.B	KMD.25.75.02.B	KMD.25.90.02.B
3	270	KMD.25.15.03.B	KMD.25.30.03.B	KMD.25.45.03.B	KMD.25.60.03.B	KMD.25.75.03.B	KMD.25.90.03.B
4	355	KMD.25.15.04.B	KMD.25.30.04.B	KMD.25.45.04.B	KMD.25.60.04.B	KMD.25.75.04.B	KMD.25.90.04.B
5	440	KMD.25.15.05.B	KMD.25.30.05.B	KMD.25.45.05.B	KMD.25.60.05.B	KMD.25.75.05.B	KMD.25.90.05.B
6	525	KMD.25.15.06.B	KMD.25.30.06.B	KMD.25.45.06.B	KMD.25.60.06.B	KMD.25.75.06.B	KMD.25.90.06.B
7	610	KMD.25.15.07.B	KMD.25.30.07.B	KMD.25.45.07.B	KMD.25.60.07.B	KMD.25.75.07.B	KMD.25.90.07.B
8	695	KMD.25.15.08.B	KMD.25.30.08.B	KMD.25.45.08.B	KMD.25.60.08.B	KMD.25.75.08.B	KMD.25.90.08.B

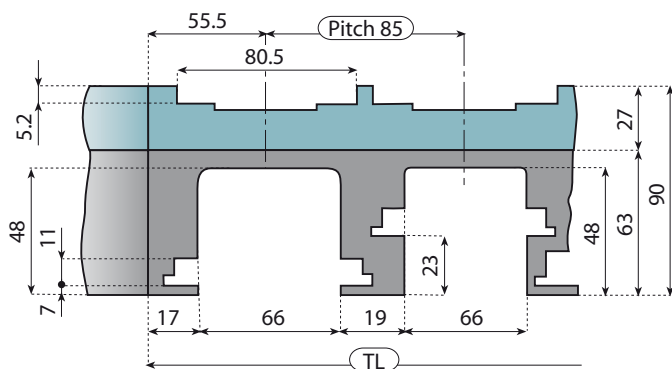

MULTI TRACKS

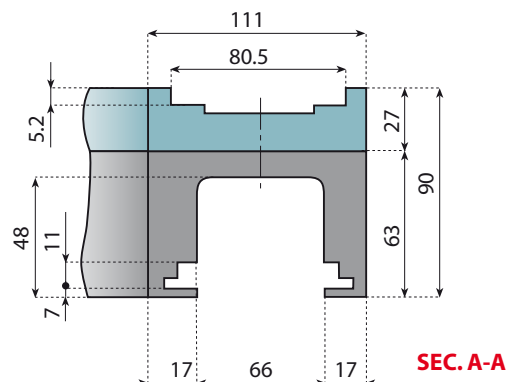

ONE TRACK

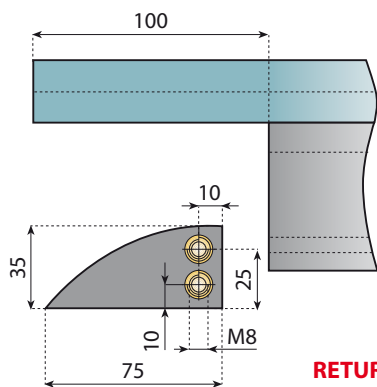

RETURN GUIDE SHOE

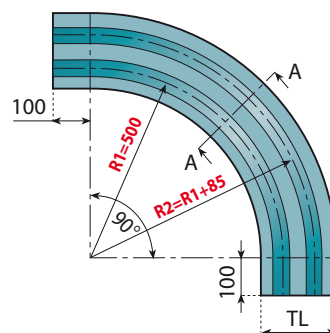

RADIUS

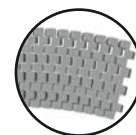

For Sideflexing Belts, type: 2120M

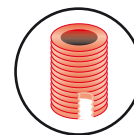

Inserts:
The magnetic corner tracks can be supplied with M8 or M10 brass inserts to your detailed drawing



Magnetic corner tracks Special Materials
On request magnetic corner tracks for high speed and extremely abrasive applications can be supplied.



Magnetic corner tracks Special Dimensions
On request magnetic corner tracks with special dimensions can be produced.



For further information contact our Technical support department.

NOW AVAILABLE IN "NOLU-S" MATERIAL !

• More tracks and different angles available on request.

Tracks	Total Width TL mm	15°	30°	45°	60°	75°	90°
1	111	KMD.26.15.01.B	KMD.26.30.01.B	KMD.26.45.01.B	KMD.26.60.01.B	KMD.26.75.01.B	KMD.26.90.01.B
2	196	KMD.26.15.02.B	KMD.26.30.02.B	KMD.26.45.02.B	KMD.26.60.02.B	KMD.26.75.02.B	KMD.26.90.02.B
3	281	KMD.26.15.03.B	KMD.26.30.03.B	KMD.26.45.03.B	KMD.26.60.03.B	KMD.26.75.03.B	KMD.26.90.03.B
4	366	KMD.26.15.04.B	KMD.26.30.04.B	KMD.26.45.04.B	KMD.26.60.04.B	KMD.26.75.04.B	KMD.26.90.04.B
5	451	KMD.26.15.05.B	KMD.26.30.05.B	KMD.26.45.05.B	KMD.26.60.05.B	KMD.26.75.05.B	KMD.26.90.05.B
6	536	KMD.26.15.06.B	KMD.26.30.06.B	KMD.26.45.06.B	KMD.26.60.06.B	KMD.26.75.06.B	KMD.26.90.06.B
7	621	KMD.26.15.07.B	KMD.26.30.07.B	KMD.26.45.07.B	KMD.26.60.07.B	KMD.26.75.07.B	KMD.26.90.07.B
8	706	KMD.26.15.08.B	KMD.26.30.08.B	KMD.26.45.08.B	KMD.26.60.08.B	KMD.26.75.08.B	KMD.26.90.08.B

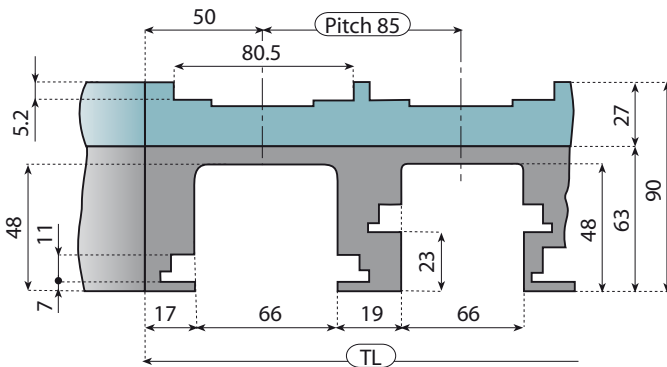

MULTI TRACKS

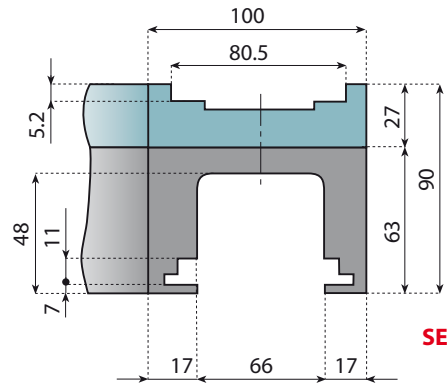

ONE TRACK

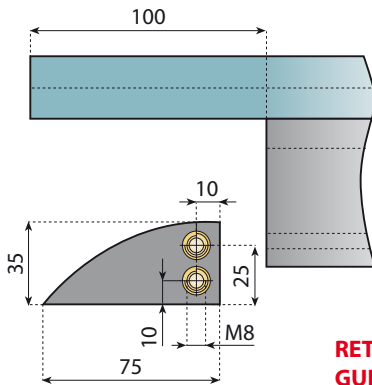

RETURN GUIDE SHOE

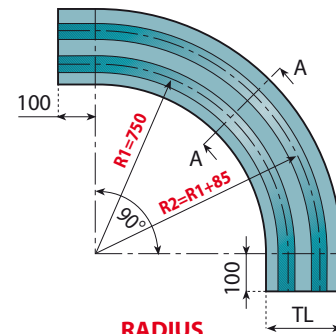

RADIUS

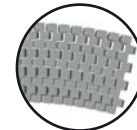

For Sideflexing Belts, type: 2120M

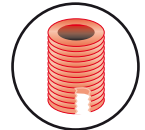

Inserts:
The magnetic corner tracks can be supplied with M8 or M10 brass inserts to your detailed drawing

NOW AVAILABLE IN
"NOLU-S"
MATERIAL !



Magnetic corner tracks Special Materials
On request magnetic corner tracks for high speed and extremely abrasive applications can be supplied.



Magnetic corner tracks Special Dimensions
On request magnetic corner tracks with special dimensions can be produced.



For further information contact our
Technical support department.

• More tracks and different angles available on request.

Tracks	Total Width TL mm	15°	30°	45°	60°	75°	90°
1	100	KMD.27.15.01.B	KMD.27.30.01.B	KMD.27.45.01.B	KMD.27.60.01.B	KMD.27.75.01.B	KMD.27.90.01.B
2	185	KMD.27.15.02.B	KMD.27.30.02.B	KMD.27.45.02.B	KMD.27.60.02.B	KMD.27.75.02.B	KMD.27.90.02.B
3	270	KMD.27.15.03.B	KMD.27.30.03.B	KMD.27.45.03.B	KMD.27.60.03.B	KMD.27.75.03.B	KMD.27.90.03.B
4	355	KMD.27.15.04.B	KMD.27.30.04.B	KMD.27.45.04.B	KMD.27.60.04.B	KMD.27.75.04.B	KMD.27.90.04.B
5	440	KMD.27.15.05.B	KMD.27.30.05.B	KMD.27.45.05.B	KMD.27.60.05.B	KMD.27.75.05.B	KMD.27.90.05.B
6	525	KMD.27.15.06.B	KMD.27.30.06.B	KMD.27.45.06.B	KMD.27.60.06.B	KMD.27.75.06.B	KMD.27.90.06.B
7	610	KMD.27.15.07.B	KMD.27.30.07.B	KMD.27.45.07.B	KMD.27.60.07.B	KMD.27.75.07.B	KMD.27.90.07.B
8	695	KMD.27.15.08.B	KMD.27.30.08.B	KMD.27.45.08.B	KMD.27.60.08.B	KMD.27.75.08.B	KMD.27.90.08.B

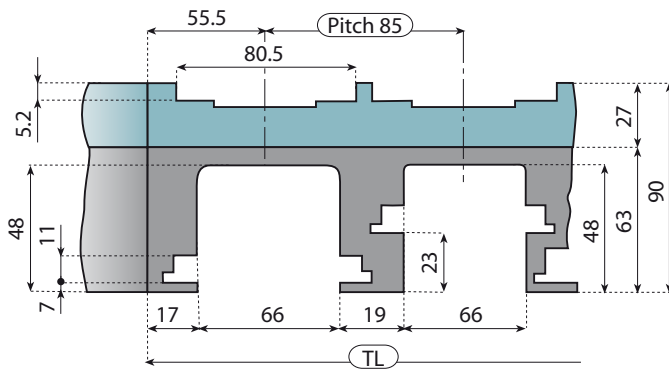

MULTI TRACKS

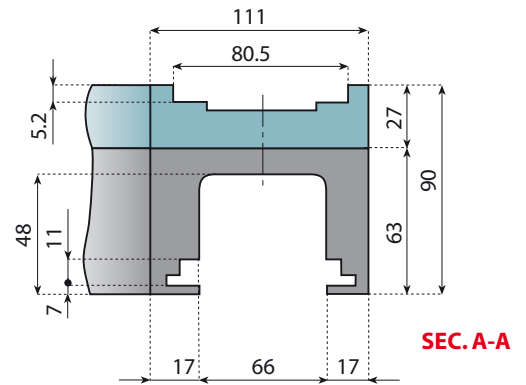

ONE TRACK

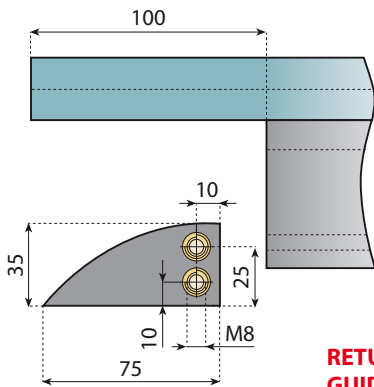

RETURN GUIDE SHOE

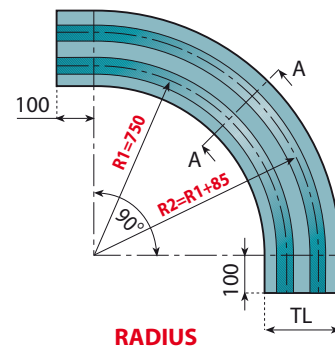

RADIUS

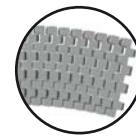

For Sideflexing Belts, type: 2120M

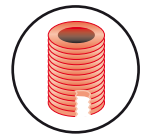

Inserts:
The magnetic corner tracks can be supplied with M8 or M10 brass inserts to your detailed drawing

NOW AVAILABLE IN "NOLU-S" MATERIAL !



Magnetic corner tracks Special Materials
On request magnetic corner tracks for high speed and extremely abrasive applications can be supplied.



Magnetic corner tracks Special Dimensions
On request magnetic corner tracks with special dimensions can be produced.



For further information contact our Technical support department.

• More tracks and different angles available on request.

Tracks	Total Width TL mm	15°	30°	45°	60°	75°	90°
1	111	KMD.28.15.01.B	KMD.28.30.01.B	KMD.28.45.01.B	KMD.28.60.01.B	KMD.28.75.01.B	KMD.28.90.01.B
2	196	KMD.28.15.02.B	KMD.28.30.02.B	KMD.28.45.02.B	KMD.28.60.02.B	KMD.28.75.02.B	KMD.28.90.02.B
3	281	KMD.28.15.03.B	KMD.28.30.03.B	KMD.28.45.03.B	KMD.28.60.03.B	KMD.28.75.03.B	KMD.28.90.03.B
4	366	KMD.28.15.04.B	KMD.28.30.04.B	KMD.28.45.04.B	KMD.28.60.04.B	KMD.28.75.04.B	KMD.28.90.04.B
5	451	KMD.28.15.05.B	KMD.28.30.05.B	KMD.28.45.05.B	KMD.28.60.05.B	KMD.28.75.05.B	KMD.28.90.05.B
6	536	KMD.28.15.06.B	KMD.28.30.06.B	KMD.28.45.06.B	KMD.28.60.06.B	KMD.28.75.06.B	KMD.28.90.06.B
7	621	KMD.28.15.07.B	KMD.28.30.07.B	KMD.28.45.07.B	KMD.28.60.07.B	KMD.28.75.07.B	KMD.28.90.07.B
8	706	KMD.28.15.08.B	KMD.28.30.08.B	KMD.28.45.08.B	KMD.28.60.08.B	KMD.28.75.08.B	KMD.28.90.08.B

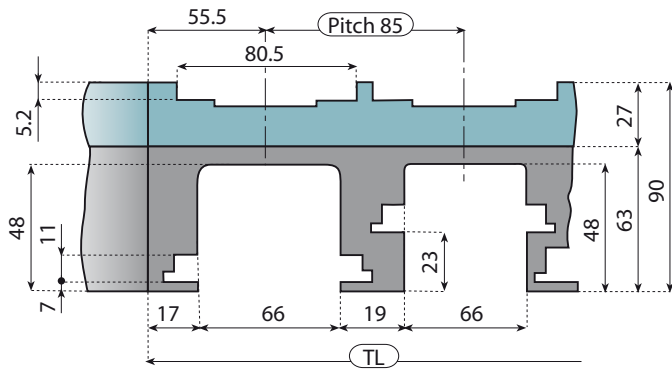

MULTI TRACKS

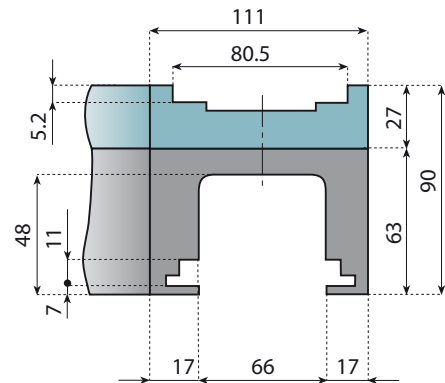

SEC. A-A

ONE TRACK

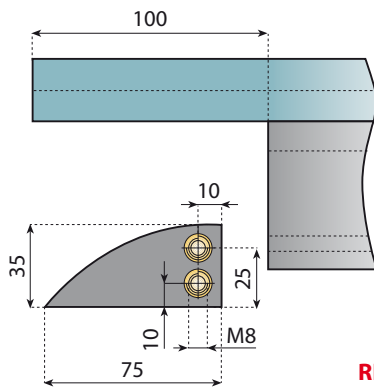

RETURN GUIDE SHOE

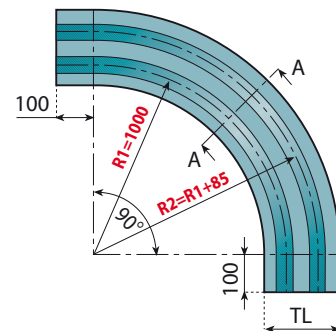

RADIUS

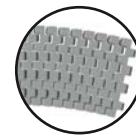

For Sideflexing Belts, type: 2120M

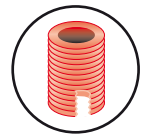

Inserts:

The magnetic corner tracks can be supplied with M8 or M10 brass inserts to your detailed drawing

NOW AVAILABLE IN "NOLU-S" MATERIAL !



Magnetic corner tracks Special Materials
On request magnetic corner tracks for high speed and extremely abrasive applications can be supplied.



Magnetic corner tracks Special Dimensions
On request magnetic corner tracks with special dimensions can be produced.



For further information contact our Technical support department.

• More tracks and different angles available on request.

Tracks	Total Width TL mm	15°	30°	45°	60°	75°	90°
1	111	KMD.29.15.01.B	KMD.29.30.01.B	KMD.29.45.01.B	KMD.29.60.01.B	KMD.29.75.01.B	KMD.29.90.01.B
2	196	KMD.29.15.02.B	KMD.29.30.02.B	KMD.29.45.02.B	KMD.29.60.02.B	KMD.29.75.02.B	KMD.29.90.02.B
3	281	KMD.29.15.03.B	KMD.29.30.03.B	KMD.29.45.03.B	KMD.29.60.03.B	KMD.29.75.03.B	KMD.29.90.03.B
4	366	KMD.29.15.04.B	KMD.29.30.04.B	KMD.29.45.04.B	KMD.29.60.04.B	KMD.29.75.04.B	KMD.29.90.04.B
5	451	KMD.29.15.05.B	KMD.29.30.05.B	KMD.29.45.05.B	KMD.29.60.05.B	KMD.29.75.05.B	KMD.29.90.05.B
6	536	KMD.29.15.06.B	KMD.29.30.06.B	KMD.29.45.06.B	KMD.29.60.06.B	KMD.29.75.06.B	KMD.29.90.06.B
7	621	KMD.29.15.07.B	KMD.29.30.07.B	KMD.29.45.07.B	KMD.29.60.07.B	KMD.29.75.07.B	KMD.29.90.07.B
8	706	KMD.29.15.08.B	KMD.29.30.08.B	KMD.29.45.08.B	KMD.29.60.08.B	KMD.29.75.08.B	KMD.29.90.08.B

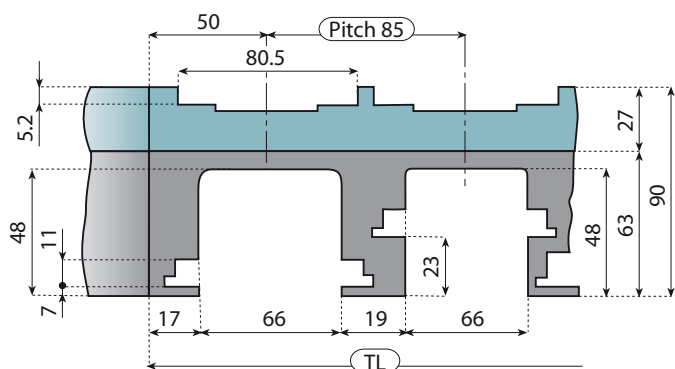

MULTI TRACKS

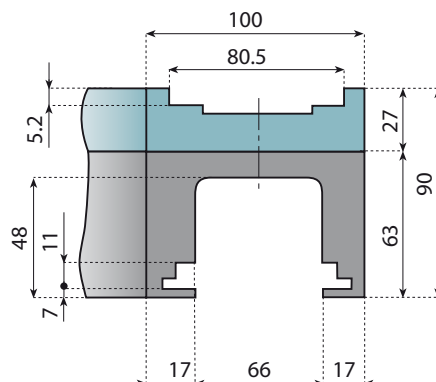

ONE TRACK

SEC. A-A

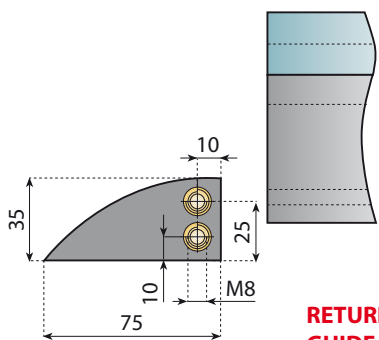

RETURN GUIDE SHOE

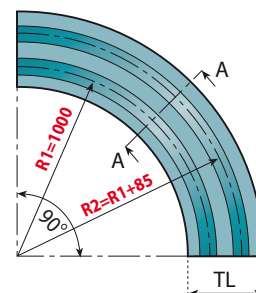

RADIUS



For Sideflexing Belts, type: 2120M

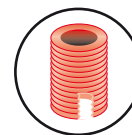

Inserts:
The magnetic corner tracks can be supplied with M8 or M10 brass inserts to your detailed drawing

NOW AVAILABLE IN
"NOLU-S"
MATERIAL !



Magnetic corner tracks Special Materials
On request magnetic corner tracks for high speed and extremely abrasive applications can be supplied.



Magnetic corner tracks Special Dimensions
On request magnetic corner tracks with special dimensions can be produced.



For further information contact our Technical support department.

• More tracks and different angles available on request.

Tracks	Total Width TL mm	15°	30°	45°	60°	75°	90°
1	100	KMD.30.15.01.A	KMD.30.30.01.A	KMD.30.45.01.A	KMD.30.60.01.A	KMD.30.75.01.A	KMD.30.90.01.A
2	185	KMD.30.15.02.A	KMD.30.30.02.A	KMD.30.45.02.A	KMD.30.60.02.A	KMD.30.75.02.A	KMD.30.90.02.A
3	270	KMD.30.15.03.A	KMD.30.30.03.A	KMD.30.45.03.A	KMD.30.60.03.A	KMD.30.75.03.A	KMD.30.90.03.A
4	355	KMD.30.15.04.A	KMD.30.30.04.A	KMD.30.45.04.A	KMD.30.60.04.A	KMD.30.75.04.A	KMD.30.90.04.A
5	440	KMD.30.15.05.A	KMD.30.30.05.A	KMD.30.45.05.A	KMD.30.60.05.A	KMD.30.75.05.A	KMD.30.90.05.A
6	525	KMD.30.15.06.A	KMD.30.30.06.A	KMD.30.45.06.A	KMD.30.60.06.A	KMD.30.75.06.A	KMD.30.90.06.A
7	610	KMD.30.15.07.A	KMD.30.30.07.A	KMD.30.45.07.A	KMD.30.60.07.A	KMD.30.75.07.A	KMD.30.90.07.A
8	695	KMD.30.15.08.A	KMD.30.30.08.A	KMD.30.45.08.A	KMD.30.60.08.A	KMD.30.75.08.A	KMD.30.90.08.A

Note:

- Sprockets with single keyway can be used for belt widths up to 680 mm and temperature differences of maximum 30°C.
- For wider belts or bigger temperature differences, sprockets with square bores or round bore with double keyway have to be used.

To order single keyway sprockets capable of floating freely on the shaft (i.e. bore tolerance DF +0.3 /+0.5), just add the letter "P" (=plus) to the existing part number. For example, code **125528GVP**.

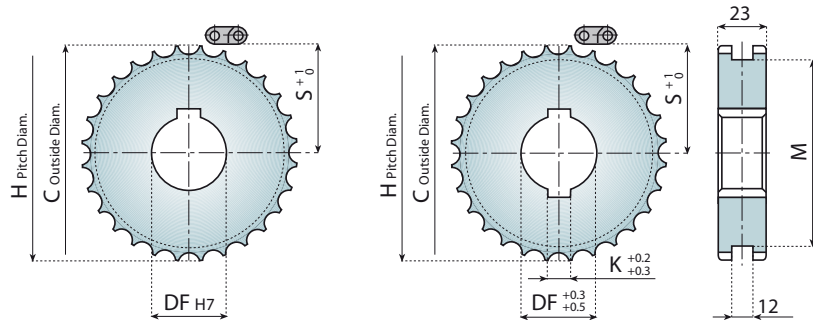

Z	C mm	H mm	M mm	S mm
14	56.9	57.06	46	24.3
16	65.2	65.10	55	28.2
20	81.2	81.19	71	36.3
24	99.3	97.30	87	44.3
28	115.4	113.4	103	52.4
36	147.7	145.7	136.02	68.5
38	155.8	153.8	143.1	72.6
40	163.85	161.85	150	76.6

STANDARD SPROCKETS SINGLE KEYWAY				
Ø 18*	Ø 25	Ø 30	Ø 35	Ø 40
PART NUMBER				
125528GV	125528V	125529V	-	-
125500GV	125500V	125501V	-	-
125502GV	125502V	125503V	125504V	125505V
125506GV	125506V	125507V	125508V	125509V
125510GV	125510V	125511V	125512V	125513V
125516GV	125516V	125517V	125518V	125519V
125520GV	125520V	125521V	125522V	125523V
125524GV	125524V	125525V	125526V	125527V

Material: polyamide.

*Plain Bore

STANDARD SPROCKETS DOUBLE KEYWAY				
-	Ø 25	Ø 30	-	-
PART NUMBER				
-	125565V	125566V	-	-
-	125551V	125552V	-	-
-	125553V	125554V	-	-
-	125555V	125556V	-	-
-	125557V	125558V	-	-
-	125559V	125560V	-	-
-	125561V	125562V	-	-
-	125563V	125564V	-	-

Material: polyamide.

To order single keyway sprockets capable of floating freely on the shaft (i.e. bore tolerance DF +0.3 /+0.5), just add the letter "P" (=plus) to the existing part number. For example, code **125600GVP**.

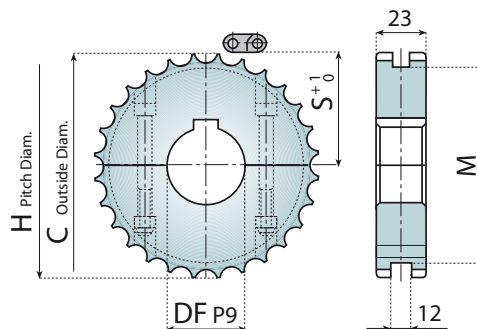

Z	C mm	H mm	M mm	S mm
28	115.4	113.4	103	52.4
36	147.7	145.7	136.02	68.5
38	155.8	153.8	143.1	72.6
40	163.85	161.85	150	76.6

SPLIT SPROCKETS SINGLE KEYWAY				
Ø 18*	Ø 25	Ø 30	Ø 35	Ø 40
PART NUMBER				
125600GV	125600V	125601V	125602V	125603V
125612GV	125612V	125613V	125614V	125615V
125604GV	125604V	125605V	125606V	125607V
125608GV	125608V	125609V	125610V	125611V

Material: polyamide, screws in stainless steel, nuts in zinc plated steel.

*Plain Bore

Note:

- Sprockets with single keyway can be used for belt widths up to 680 mm and temperature differences of maximum 30°C.
- For wider belts or bigger temperature differences, sprockets with square bores or round bore with double keyway have to be used.

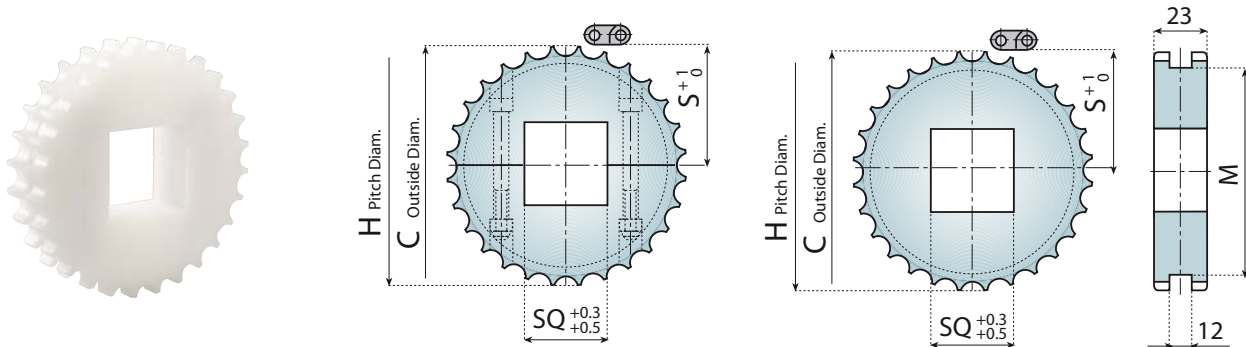

 SPLIT SPROCKETS SQUARE BORE				
30x30	35x35	40x40	60x60	
PART NUMBER				
-	-	-	-	
-	-	-	-	
-	-	-	-	
-	-	-	-	
125650V	-	125651V	-	
125652V	-	125653V	125654V	
125655V	-	125656V	125657V	
125658V	-	125659V	125660V	

 STANDARD SPROCKETS SQUARE BORE					
20x20	25x25	30x30	35x35	40x40	60x60
PART NUMBER					
125720V	125721V	-	-	-	-
-	125700V	125701V	-	-	-
-	125702V	125703V	125704V	-	-
-	125705V	125706V	-	125707V	-
-	125708V	125709V	-	125710V	-
-	-	125711V	-	125712V	125713V
-	-	125714V	-	125715V	125716V
-	-	125717V	-	125718V	125719V

Material: polyamide, screws in stainless steel, nuts in zinc plated steel.

Material: polyamide.

Features:

- These sprockets float freely on the shaft.

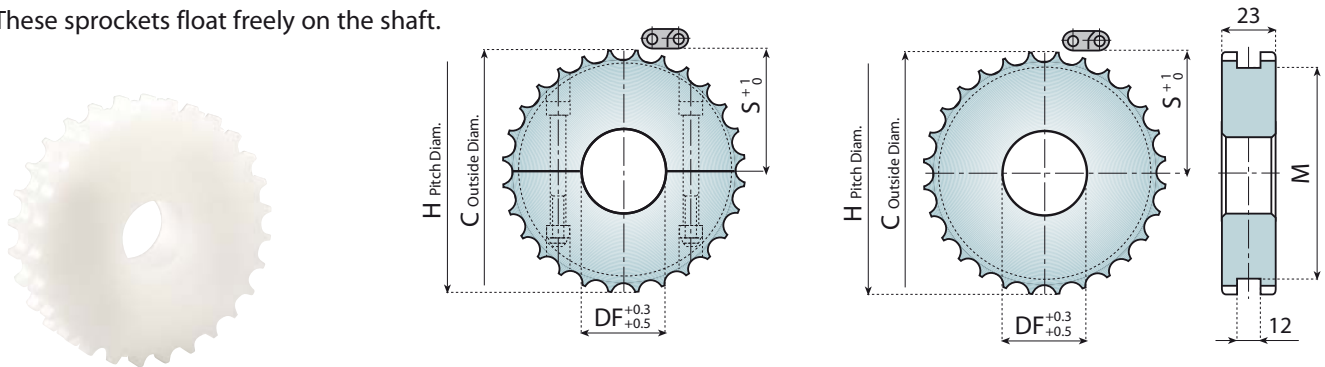

Z	C mm	H mm	M mm	S mm
14	56.9	57.06	46	24.3
16	65.2	65.10	55	28.2
20	81.2	81.19	71	36.3
24	99.3	97.30	87	44.3
28	115.4	113.4	103	52.4
36	147.7	145.7	136.02	68.5
38	155.8	153.8	143.1	72.6
40	163.85	161.85	150	76.6

 SPLIT IDLER WHEELS				
Ø 18*	Ø 25	Ø 30	Ø 35	Ø 40
PART NUMBER				
-	-	-	-	-
-	-	-	-	-
-	-	-	-	-
-	-	-	-	-
125600GV	125600RV	125601RV	125602RV	125603RV
125612GV	125612RV	125613RV	125614RV	125615RV
125604GV	125604RV	125605RV	125606RV	125607RV
125608GV	125608RV	125609RV	125610RV	125611RV

 STANDARD IDLER WHEELS				
Ø 18*	Ø 25	Ø 30	Ø 35	Ø 40
PART NUMBER				
125528GV	125528RIV	125529RIV	-	-
125500GV	125500RIV	125501RIV	-	-
125502GV	125502RIV	125503RIV	125504RIV	125505RIV
125506GV	125506RIV	125507RIV	125508RIV	125509RIV
125510GV	125510RIV	125511RIV	125512RIV	125513RIV
125516GV	125612RIV	125613RIV	125614RIV	125615RIV
125520GV	125604RIV	125605RIV	125606RIV	125607RIV
125524GV	125608RIV	125609RIV	125610RIV	125611RIV

Material: polyamide, screws in stainless steel, nuts in zinc plated steel.

Material: polyamide.

*Plain Bore

*Plain Bore

Note:

- Sprockets with single keyway can be used for belt widths up to 680 mm and temperature differences of maximum 30°C.
- For wider belts or bigger temperature differences, sprockets with square bores or round bore with double keyway have to be used.

To order single keyway sprockets capable of floating freely on the shaft (i.e. bore tolerance DF +0.3 /+0.5), just add the letter "P" (=plus) to the existing part number. For example, code **12300VP**.

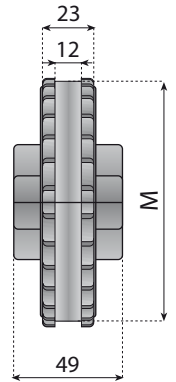
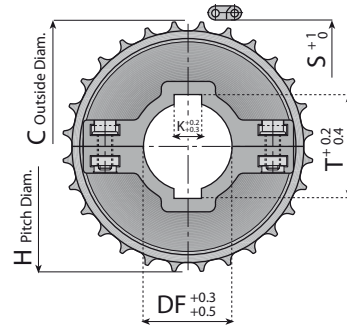
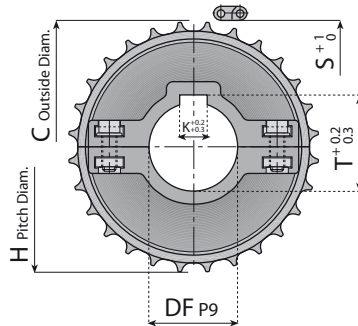

Z	C mm	H mm	M mm	S mm
24	99.3	97.3	87	44.3
28	115.4	113.4	103	52.4
36	147.7	145.7	136.02	68.5

SPLIT SPROCKETS SINGLE KEYWAY				
-	Ø 30	Ø 35	Ø 40	Ø 45
PART NUMBER				
-	123190V	123191V	123192V	-
-	123000V	123001V	123002V	123003V
-	123200V	-	123201V	-

SPLIT SPROCKETS DOUBLE KEYWAY				
-	Ø 30	Ø 35	Ø 40	Ø 45
PART NUMBER				
-	123193V	123194V	123195V	-
-	123004V	123005V	123006V	123007V
-	123202V	-	123203V	-

Material: reinforced polyamide, screws in stainless steel, nuts in nickel plated brass.

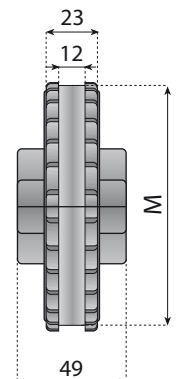
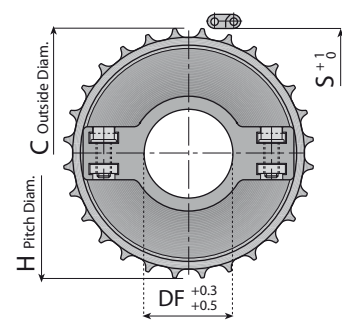
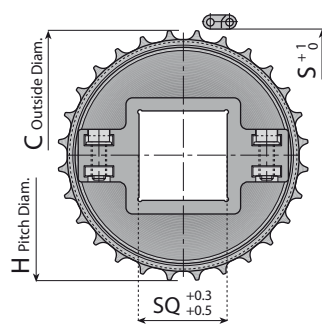

Z	C mm	H mm	M mm	S mm
24	99.3	97.3	87	44.3
28	115.4	113.4	103	52.4
36	147.7	145.7	136.02	68.5

SPLIT SPROCKETS SQUARE BORE				
-	30x30	40x40	-	-
PART NUMBER				
-	123196V	-	-	-
-	123008V	123009V	-	-
-	-	-	-	-

SPLIT IDLER WHEELS				
-	Ø 30	Ø 35	Ø 40	Ø 45
PART NUMBER				
-	123197V	123198V	123199V	-
-	123010V	123011V	123012V	123013V
-	123204V	-	123205V	-

Material: reinforced polyamide, screws in stainless steel, nuts in nickel plated brass.



Conveyor Line

A vast range of versatile components, idler wheels, turning disks, heads, caps, supports and many more.



Bearing Line

Shafts supports: strong, highly reliable and sealed, stand up to wear and time, are available in flanged, straight, sliding and pendant versions.

Nolu-Clean®



Presso Line

A vast range of feet: articulated and fixed, anti-slip, antivibration, with or without holes for clamping, products for supporting and levelling machines.



Silver Line

This line of products will increase the options available to the customer adding a line in stainless steel to support our existing Conveyor Line.



System Frame

A complete range of profiles, connecting joints and accessories, with limitless possibility of use.



System Chains

Combined with components, versatile and stable slat band chains create high efficiency systems.



Modular Plastic Belts

Modular conveying belts and accessories stand as the completion and improvement of the traditional slat band chains.



www.systemplast.com

System Plast S.p.A. - ITALY
24060 Telgate (Bergamo) - ITALY
Telephone 035.83.51.301
Telefax 035.83.51.406
info@systemplast.com

Flexon System Plast - GERMANY
Tel. (03529) 56.15.0
Fax (03529) 51.13.67
info@fspchains.com

Flexon System Plast - GERMANY
Sales Office - GERMANY
Tel. (06204) 9673.0
Fax (06204) 9673.29
info-de@systemplast.com

Sytem Plast s.a. - FRANCE
Tel. (01) 64.66.05.48
Fax (01) 64.66.05.82
info-fr@systemplast.com

System Plast International THE NETHERLANDS
Tel. (0186) 63.61.21
Fax (0186) 63.61.25
info-nl@systemplast.com

System Plast - ENGLAND
Tel. (01926) 614.314
Fax (01926) 614.914
info-uk@systemplast.com

Solus - USA - EAST
Tel. (919) 775.5716
Fax (919) 775.5720
solusteam@solusii.com

Solus - USA - WEST
Tel. (949) 589.3900
Fax (949) 858.0300
solusteam@solusii.com

Solus System Plast - MEXICO
Tel. (033) 3687-2525
Fax (033) 3687-2626
info-mx@systemplast.com

System Plast - BRAZIL
Tel. (011) 3849.48.46
Fax (011) 3845.46.02
info-br@systemplast.com

System Plast - SINGAPORE
Tel. (65) 6339.3919
Fax (65) 6339.3932
info-sg@systemplast.com